



# User Manual

## L200PRO Dehumidification Kiln



© 2023 Nyle Dry Kilns  
L200PRO Manual  
Rev 2023.03

[www.nyle.com](http://www.nyle.com) - [kilnsales@nyle.com](mailto:kilnsales@nyle.com) - (800) 777-6953



# Table of Contents

---

<b>Safety Guidelines</b> .....	1
<i>Precautions</i> .....	1
<i>Electrical Grounding</i> .....	1
<b>Your Kiln</b> .....	2
<i>How your Dehumidification Kiln Works</i> .....	2
<b>Getting Started</b> .....	2
Floors.....	2
Ceilings.....	2
Doors.....	2
Construction Guidelines .....	3
Baffles and Deflectors .....	3
Power Vent .....	3
<b>Chamber Plans</b> .....	4
Chamber Dimensions .....	7
Wall Details .....	8
Front Elevation .....	9
Door Framing .....	10
Deflectors and Baffles .....	14
Power Vent Wiring .....	15
Fan Diagram .....	15
<b>Equipment Installation</b> .....	16
<b>Sensors</b> .....	16
Digital Sensor .....	16
Additional Probes .....	16
Digital Sensor Installation .....	16
<b>L200PRO Kiln Control</b> .....	16
What is New to The L200PRO .....	16
L200PRO Operation Modes .....	17
Basic Operation .....	17
<b>Screens</b> .....	18
Start-up screen (Main Screen) .....	18
Mode Selection .....	18
MC% Screen .....	18
Advanced Screen .....	19
Unit Data .....	19
<b>Operation Modes</b> .....	20
DH Mode .....	20
Hybrid Schedule Mode .....	20
Heat Treat Mode .....	21
Dump Cycle Mode .....	21
<b>Equalizing &amp; Conditioning</b> .....	22
<b>Graphs</b> .....	22
Process Graphs .....	22
HT Graphs .....	22
Saving a Graph .....	22

<b>Alarming</b> .....	23
<b>Accessing Data on the Controller</b> .....	23
Setting Date & Time .....	24
Transferring Files to USB .....	24
<b>Drying Lumber</b> .....	25
Placing Stickers and Loading Lumber.....	25
Ensuring Proper Airflow .....	25
Drying Schedules .....	25
Wood Groups .....	26
Lumber Types .....	26
Moisture Removal Rates .....	26
L200 Drying Schedules .....	26
Drying Rates (North American Measure) .....	27
Drying Rates (Metric) .....	28
Kiln Sample Boards .....	29
Uses for Sample Boards .....	29
Taking Samples .....	29
Record Keeping.....	30
Drying Rate Index (DRI) .....	30
Drying Tips .....	31
<b>Nyle Drying Charts</b> .....	33
<b>Kiln Carts</b> .....	35
Kiln Cart Layout .....	35
Kiln Cart Assembly .....	35
<b>Wiring Diagrams</b> .....	36
<b>L200 Maintenance</b> .....	43
General Maintenance .....	43
Air Inlet Filters .....	43
Refrigerant Charging Procedure .....	43
<b>Appendix</b> .....	43
Terminology .....	43
<b>Troubleshooting</b> .....	44
<b>Upgrades &amp; Accessories</b> .....	45
Spray Systems Kit .....	45
Heat Booster Package .....	45
<b>Kiln Store</b> .....	46
<b>Warranty</b> .....	46

**⚠️ WARNING** Read through entire manual before installing, operating, or servicing this unit. Failure to follow any steps or guidelines could result in personal injury, death, destruction of property or may cause the unit to become inoperable. These are the "original Instructions for this unit." **This manual must be kept with the unit at all times.**

## Safety Guidelines

### Precautions

Do not operate if the unit or any of its parts:

- Have been exposed to fire.
- Have been submerged in or exposed to excessive water.
- Has significant interior or exterior damage.

If any of the above are suspected make sure to have your unit serviced by a qualified professional before continuing operation.

\*The unit is rated for an ambient temp of 10-40° C, 80 RH % at a maximum 200 meters.

### Electrical Grounding

The unit must be grounded.

Failure to ground the unit will result in unreliable performance or an inoperative unit. You can ground the unit by connecting the unit to a grounded metal, permanent wiring system. Make sure the unit is in accordance with national and local electrical codes. If you don't know the building codes in your area or need more information, please contact your municipal office.

\*Normally airborne noise is rated at 77 dB.

### ⚠️ WARNING Refrigerant!

- Unit contains R-134a refrigerant under high pressure. Refrigerant must be recovered to relieve pressure before servicing.
- DO NOT use unapproved refrigerants, substitutes or additives.
- Failure to abide by these guidelines can result in death, injury and property damages.
- Contact Nyle's service department for more information on refrigerant options.

### ⚠️ WARNING

#### High Temperatures!



- Kiln chamber can reach internal temperatures of over 90°F. Working in these temperatures can cause heat stroke and minor burns.
- Pregnant women, children, the elderly and those with significant health issues are at higher risk of heat stroke and must be supervised in high temperatures.
- Kiln operators should check for temperature and take proper safety precautions before entering the kiln chamber.

### ⚠️ WARNING

#### Electrical Shock!

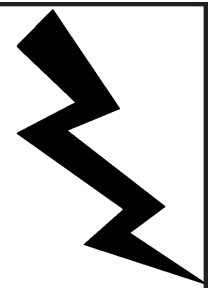

- Turn off power to unit before service.
- Make sure wires are labeled before disconnecting.
- Test unit after reconnecting wires.
- Failure to do the above could result in death or injury.

### ⚠️ WARNING

#### Explosion Hazard!

- DO NOT purge or pressurize this system with oxygen to test for leakage. Using oxygen may cause explosive reaction.



### ⚠️ WARNING Supervision!

- The appliance is not to be used by person (including children) with reduced physical, sensory or mental capabilities, or lack of experience and knowledge, unless they have been given supervision or instruction.
- Supervised children are not to play with the appliance.



## Your Kiln

---

### How your Dehumidification Kiln Works

Thank you for purchasing a Nyle DH Kiln and taking the first step towards making the lumber industry cleaner and more efficient! Years of development, innovation, and the highest quality materials have gone into building your kiln. It's our dedication to efficiency that sets Nyle kilns apart from the rest, making your system the best on the market.

During kiln drying, moisture from green lumber is evaporated into the air, increasing the humidity inside the chamber. The lumber can't continue to dry if the air becomes over-saturated. Therefore the moisture must be periodically removed from the chamber. In a conventional kiln, moisture would be expelled through venting. Venting causes a significant loss of heat, resulting in a waste of energy to bring the kiln back up to temperature.

Instead of venting, Nyle Dehumidification Kilns utilize a refrigeration system that condenses the excess moisture. This moisture is then drained off, retaining the existing heat energy. After the moisture is removed and heat is reintroduced to the dry air, it is pumped back into the kiln chamber to start the process over. Unlike conventional kilns, the heater in your Nyle Kiln is only used during the initial warm-up. Sometimes, temperature increases are desired during the cycle, saving you time and money. But that's not all your new kiln has to offer!

Though Nyle kilns don't rely on venting to remove moisture, a Vent System is supplied to add extra control of your kiln temperature. If the internal kiln temperature exceeds what's required, these vents can be opened to remove excess heat and bring the temperature back to where it needs to be.

Finally, Nyle Systems offers a wide variety of upgrades and accessories to enhance your kiln drying experience. See the upgrades and accessories section on page 45 for more information. By purchasing a Nyle Kiln, you have the support of Nyle's service team, the very same professionals that built and tested your unit. Enjoy your new system!

## Getting Started

---

*Please read through carefully as some options may not apply.*

### Floors

A Concrete floor with insulation installed underneath is recommended for best results. However, if the kiln will be on an existing concrete floor, the insulation may be omitted. Concrete must not extend beyond the kiln walls.

Wood floors may be used but must be built to construction guidelines (see Pg 3)

### Ceilings

If the kiln chamber is a freestanding outside building, the attic space must be well ventilated through the eaves. This is done to avoid any moisture buildup in this space, which will condense on the cold roof and drip onto the insulation.

An interior kiln can have the ceiling insulation open to the atmosphere.

The ceilings must be built to construction guidelines. (Pg 3)

### Doors

At the front of the kiln chamber, install bay/loading doors with at least two sides hinges and a center door latch to close (recommended). Top hinged or lift-off doors are also acceptable.

At least one access door should be installed in the back of the chamber to allow dehumidifier servicing and/or lumber monitoring.

All installed doors must:

- Be built to construction guidelines. However, they may be lightened by increasing the stud spacing and using 3/8" plywood. The lighter weight will reduce the load on the hinges.
- Have a vapor barrier.
- Have gaskets wherever the door meets the kiln; this will give a good, airtight fit.
- Have a scraper-type weather strip to reduce air leakage if the door sill is not present.

- Close tightly against the gasket using turn-buckles, tarp straps, lag studs with wing nut, etc.

Remember: There will be considerable expansion and contraction during kiln use, so it is imperative to plan your kiln door construction accordingly.

While outside electronic moisture meters can be used to avoid entering the kiln during the drying cycle, Nyle strongly recommends regular checks inside the kiln to visually inspect the surface or ends for checks, mold, stain, as well as testing with a handheld meter.

## Construction Guidelines

*Please reference "The Chamber Plans" for more information on construction.*

Step 1: Build all walls, ceilings, and floors with a 2" x 4" framework using blue or pink Styrofoam (extruded polystyrene) friction fitted between the studs.

Step 2: Cover the interior face of the studs with a 1" layer of Celotex Thermax ( for better results, overlap two ½" layers).

Celotex Thermax is a foil-faced polyisocyanurate (urethane) board that is orange or yellow and is available in 4' x 8' sheets of various thicknesses. Celotex Thermax is a trade name; similar products under other names are acceptable.

*Note: If you want to use spray foam insulation, only use urethane-based spray foam applied at 2.2lb/cu ft. Fiberglass is never recommended.*

Step 3: Caulk joints and nail heads with a high-temperature silicone (optional: apply aluminum tape over silicone)

Step 4: Cover Thermax with one or two layers of 6 mil polyethylene, then enclose with ½" CDX or marine grade plywood.

Step 5: Coat CDX interior surface with "mobile home or metal roofing aluminum paint"

*Note: Paint is an asphalt-based coating with powdered aluminum and fiber for strength, available in most hardware stores. Re-coat as necessary every year.*

Step 6: Finish exterior walls to suit your tastes, but avoid galvanized steel or other ferrous sidings.

Once you have completed the construction of the kiln chamber, install the following air deflectors and baffles to control the airflow within the chamber.

## Baffles and Deflectors

Do not underestimate the effect of baffling. Correct baffling will result in faster and more even drying. The benefits more than offset the extra time and effort to place the baffles correctly.

Corner deflectors: typically made of plywood, are used to help turn the airflow.

Top Baffle: A hinged baffle that falls from the fan wall to the top of the load used to compensate for different load sizes and allow for shrinkage of the board pile.

Side Baffle: A baffle that closes in the open space when the lumber does not fill the entire width. This baffle can be fixed or portable.

Please reference pg 14 for more information on deflectors and baffles.

## Power Vent

The Power Vent is to be secured to the inside of the kiln wall with the fan side facing the exterior.



# Do It Yourself Chamber Plans

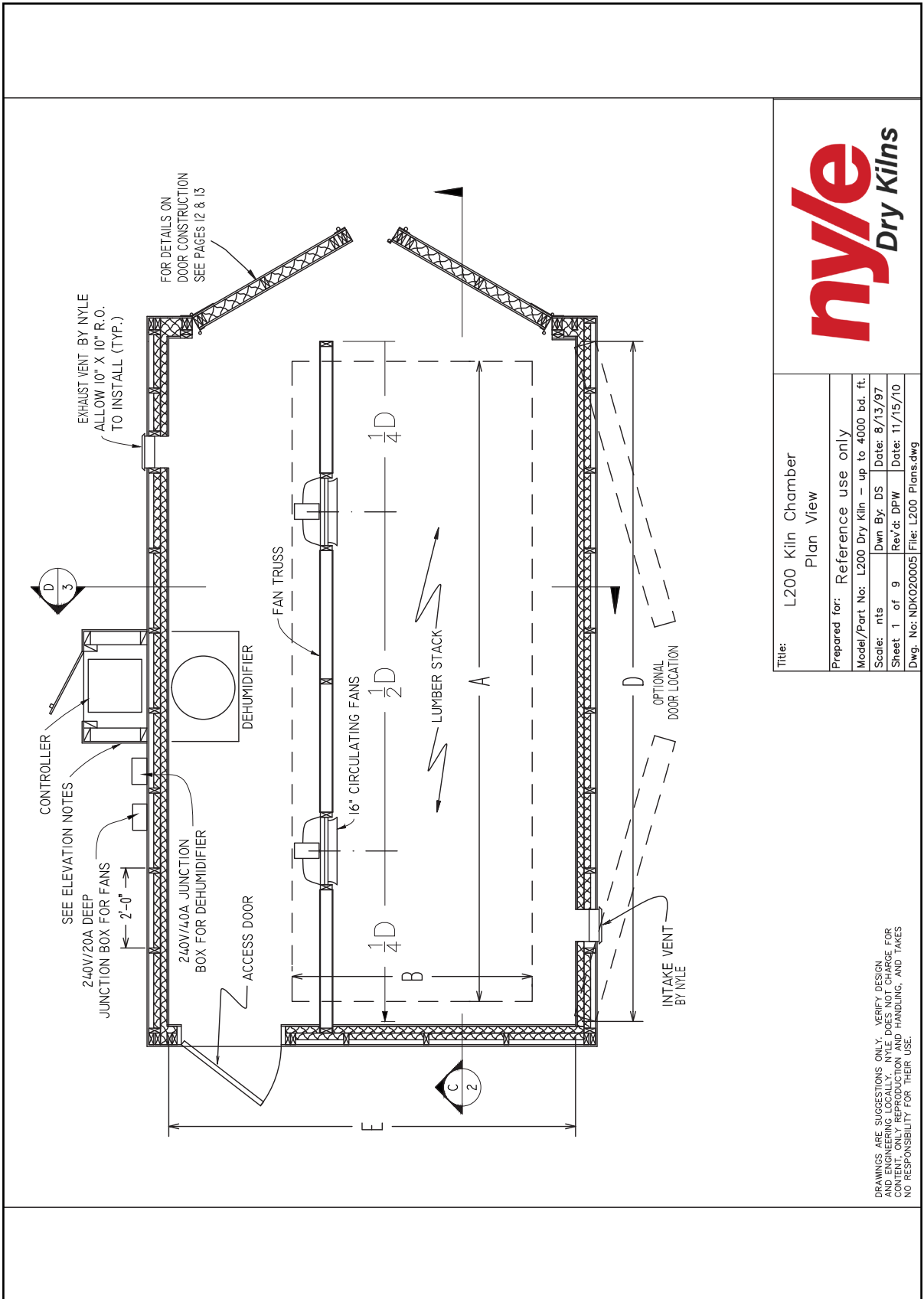

Title: L200 Kiln Chamber Plan View	
Prepared for: Reference use only	
Model/Part No: L200 Dry Kiln - up to 4000 bd. ft.	Dwn By: DS
Scale: nts	Date: 8/13/97
Sheet 1 of 9	Rev'd: DPW
Date: 11/15/10	
Dwg. No: NDK020005   File: L200 Plans.dwg	

DRAWINGS ARE SUGGESTIONS ONLY. VERIFY DESIGN AND ENGINEERING LOCALLY. NYLE DOES NOT CHARGE FOR CONTENT, ONLY REPRODUCTION AND HANDLING, AND TAKES NO RESPONSIBILITY FOR THEIR USE.





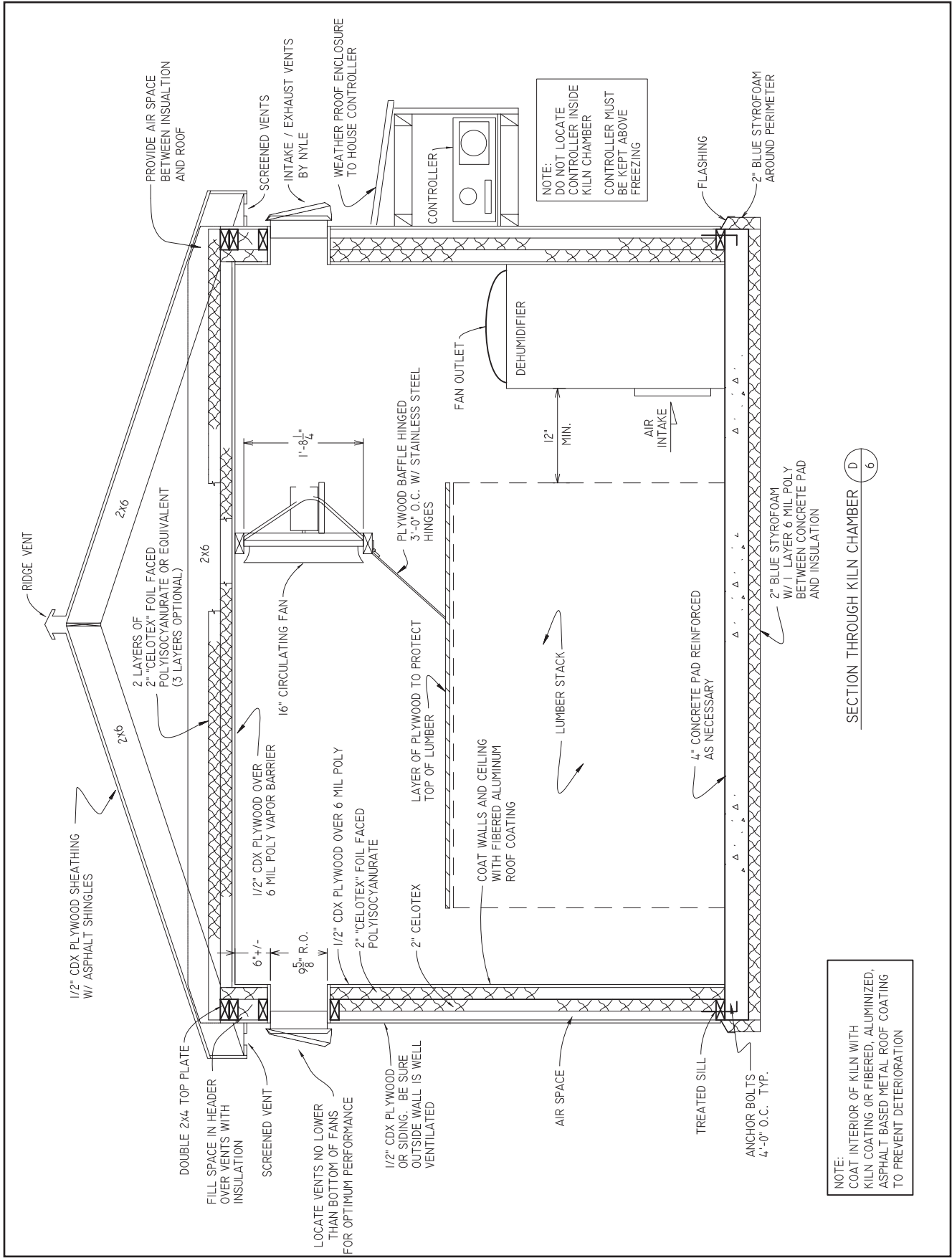

SECTION THROUGH KILN CHAMBER D  
6

NOTE:  
 INTERIOR OF KILN WITH  
 COAT COATING OR FIBERED, ALUMINIZED,  
 ASPHALT BASED METAL ROOF COATING  
 TO PREVENT DETERIORATION



# Wall Details

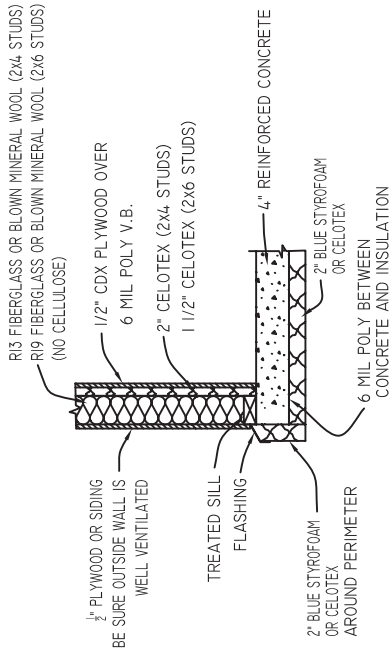

ALTERNATIVE WALL/CONCRETE FLOOR DETAIL

NOTE:  
ALTERNATIVE CONSTRUCTION  
METHODS MAY BE USED IN  
WALLS AND CEILING.

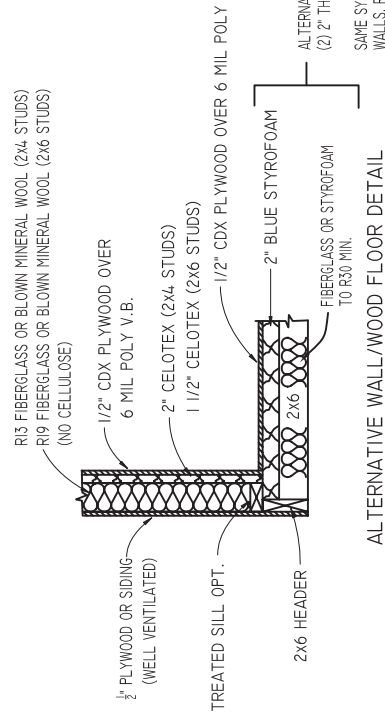

ALTERNATIVE WALL/WOOD FLOOR DETAIL

NOTE:

- 1) POLYISOCYANURATE INSULATION BOARD (CELOTEX, THERMAX, OR TUFF-R) IS STRONGLY RECOMMENDED FOR INTERIOR INSULATION SHEATHING. 1" IS SHOWN BUT THICKER IS PREFERRED ESPECIALLY IF USING FIBERGLASS OR BLOWN MINERAL WOOL INSULATION.
- 2) DO NOT USE CELLULOSE OR EXPANDED POLYSTYRENE (WHITE STYROFOAM) INSULATION IN THE DRYING KILN
- 3) ALL INTERIOR FASTENERS SHOULD BE STAINLESS STEEL.
- 4) INSTALL INTAKE/EXHAUST VENTS AT CONVENIENT ELEVATION TO ALLOW FOR MANUAL ADJUSTMENT.
- 5) POWERED VENT SYSTEM AVAILABLE. CONTACT NYLE. FIT SAME ROUGH OPENINGS.
- 6) COAT INTERIOR WALL AND CEILING SURFACES WITH FIBERED ALUMINUM ROOF COATING.

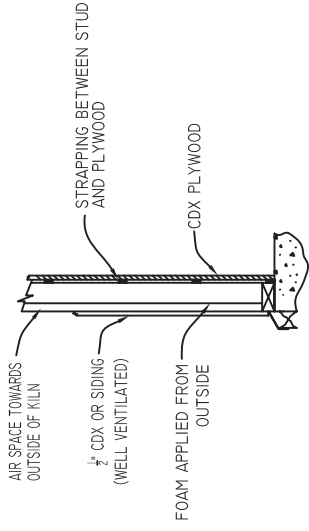

ALTERNATIVE STUD WALL SECTION

SPRAYED URETHANE FOAM

URETHANE FOAM MUST BE APPLIED IN  
MULTIPLE APPLICATIONS AT A MAXIMUM DEPTH  
OF 1 1/2" PER COAT. A MINIMUM OF 4" OF FOAM  
IS REQUIRED AT A DENSITY OF 2.2 LBS PER CUBIC  
FOOT TO MEET THE R30 INSULATION REQUIREMENT.

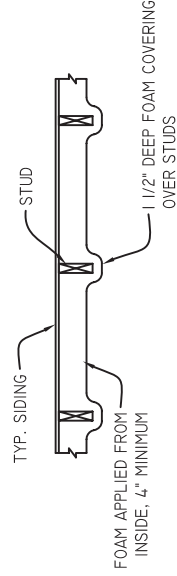

ALTERNATIVE STUD WALL SECTION

# Front Elevation

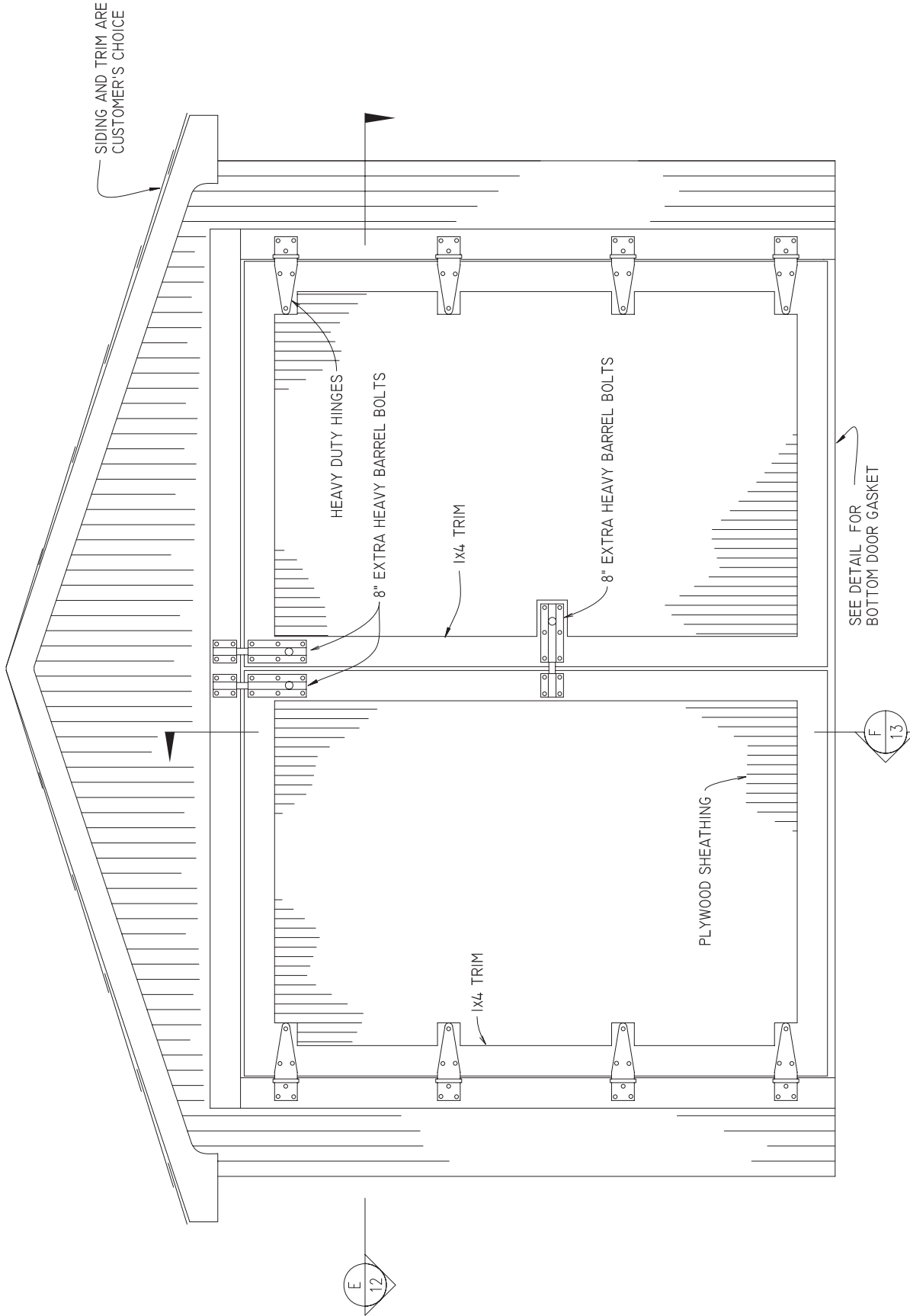



# Door Framing

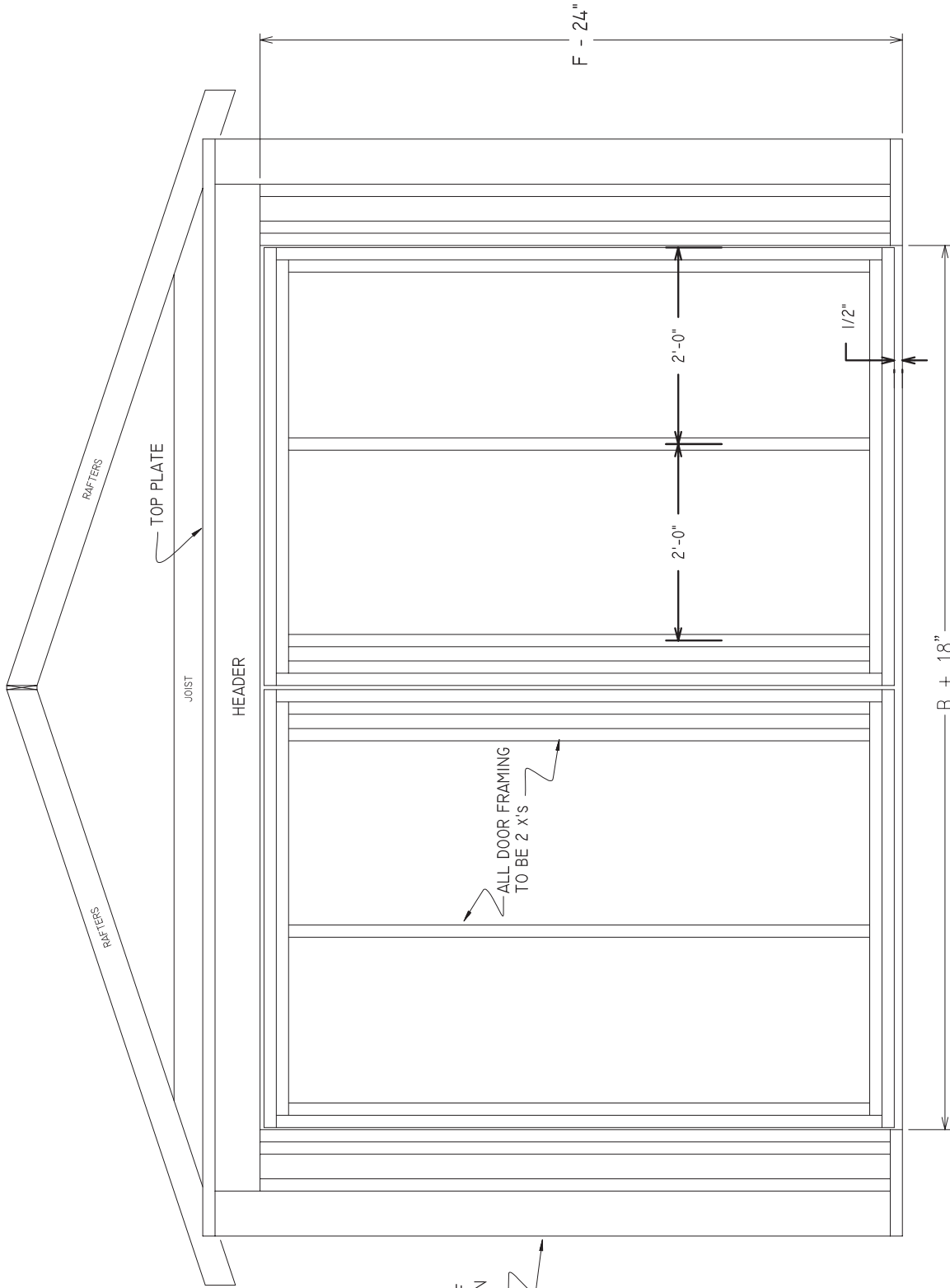

FRONT WALL AND DOOR FRAMING

NOTE:  
 USE 2X4s AT WALLS  
 TO ALLOW FOR 4" OF  
 CELOTEX INSULATION  
 BETWEEN WALLS

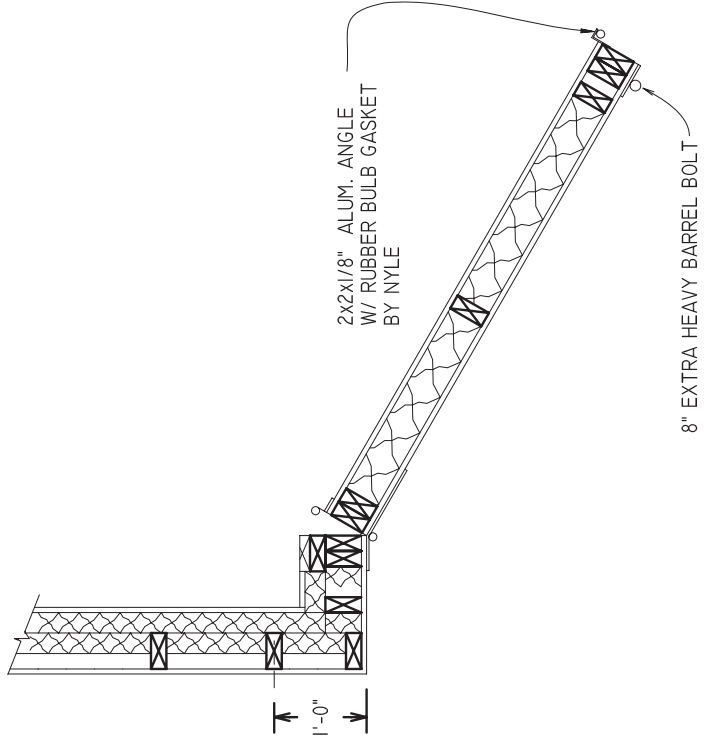
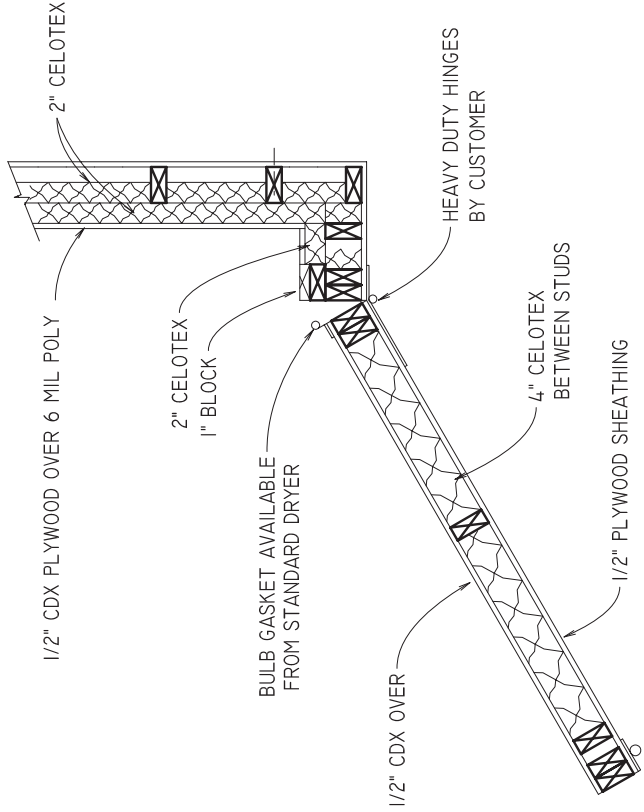

NOTE:  
 COAT INTERIOR OF KILN WITH KILN COATING  
 COAT (FIBERED, ALUMINIZED ASPHALT BASED METAL  
 ROOF COATING) TO PREVENT DETERIORATION.

SECTION FRONT WALL OF KILN CHAMBER  
 W/ 2 SWINGING DOORS

E  
 12

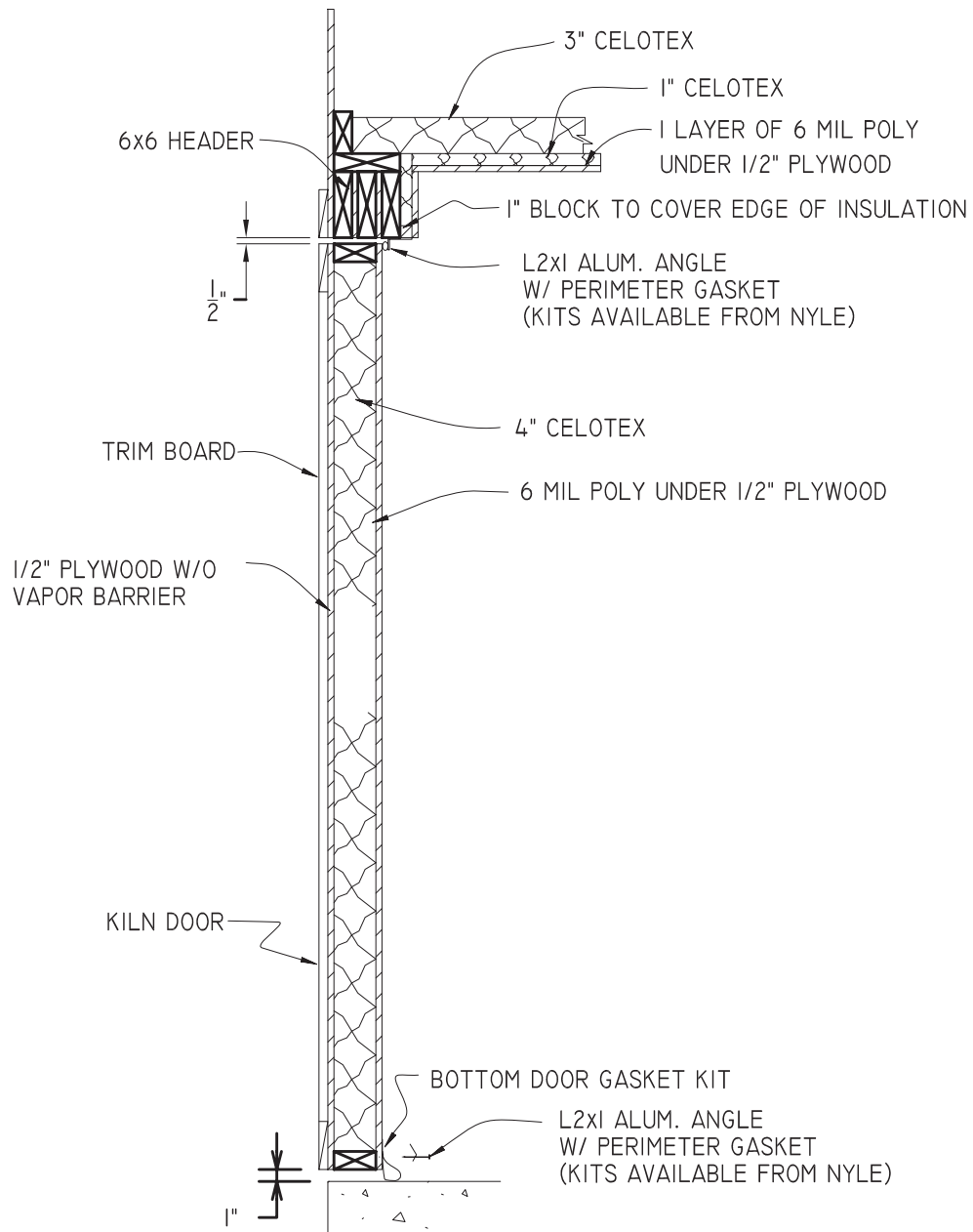

SECTION KILN DOOR AND HEADER F  
13

GASKETS AND DOOR KITS AVAILABLE

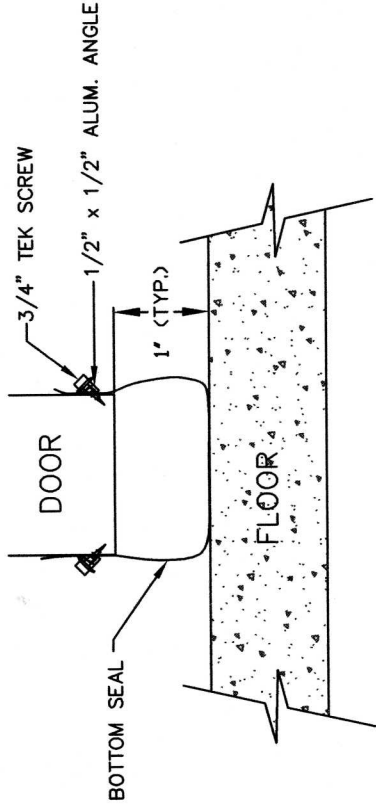

INSTALLATION OF BOTTOM DOOR GASKET

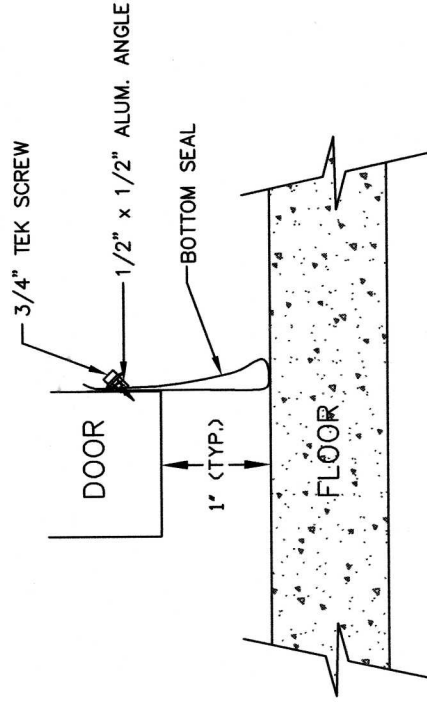

ALTERNATE INSTALLATION OF  
BOTTOM DOOR GASKET

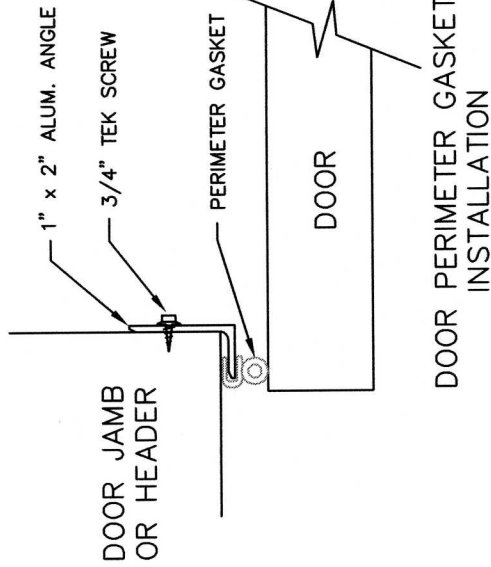

DOOR PERIMETER GASKET  
INSTALLATION

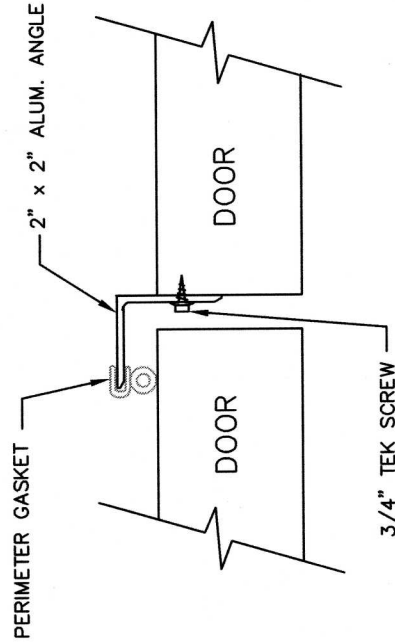

INSTALLATION OF CENTER DOOR GASKET

ADJUST ANGLE INSTALLATION SO THAT  
GASKET IS SLIGHTLY COMPRESSED

# Deflectors and Baffles

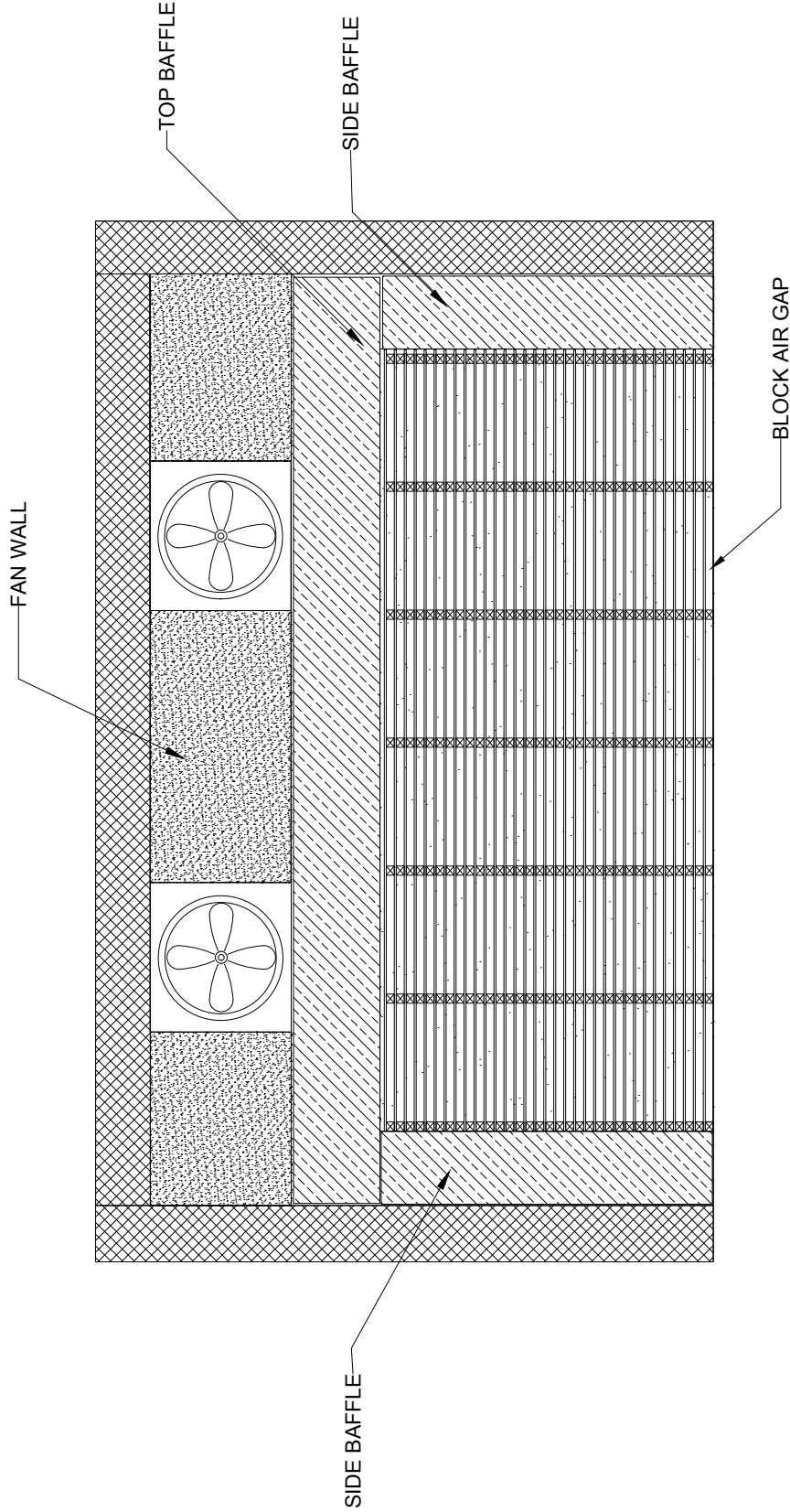

**STACKING & BAFFLING**  
CLOSE ALL LARGE AIR GAPS SO THAT AIR CAN ONLY PASS THROUGH THE STICKER SPACE  
CAREFULLY ALIGN STICKERS VERTICALLY  
HANGED BAFFLE FROM FANWALL TO FRONT EDGE OF LUMBER STACK



## Power Vent Wiring

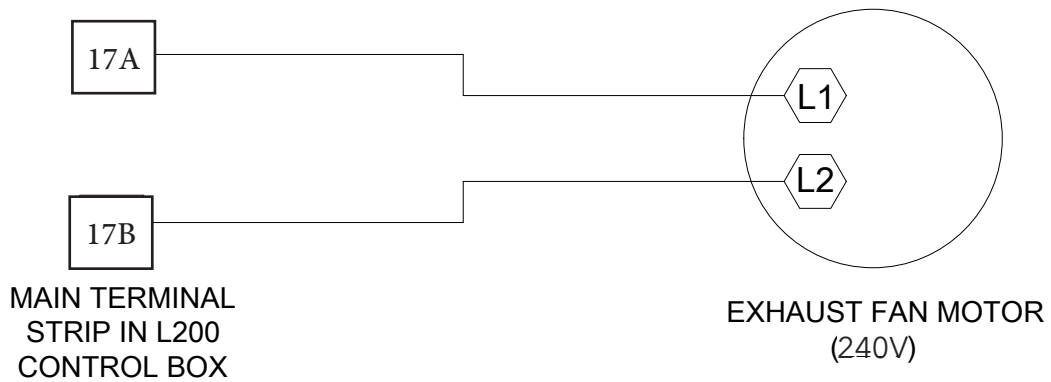

## Fan Diagram

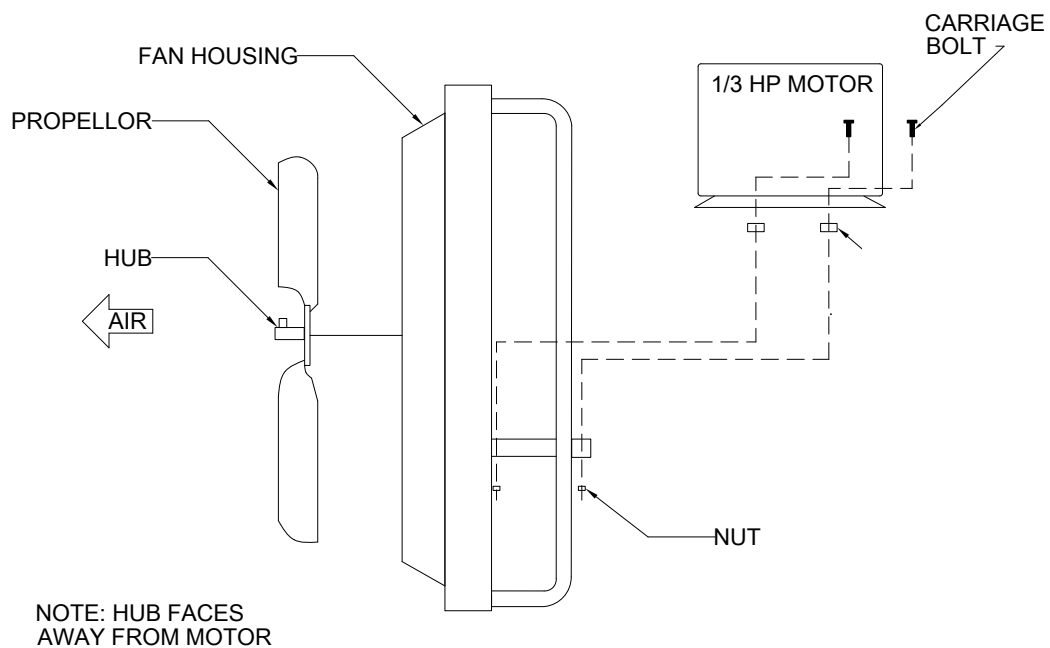

1. MOUNT MOTOR ON BASE USING BOLTS AND NUTS PROVIDED
2. PLACE FAN ON MOTOR SHAFT SO THAT ONE SCREW SET MEETS THE FLAT OF THE SHAFT. TIGHTEN BOTH SET SCREWS
3. ADJUST THE MOTOR SO THAT THE TIO OF THE BLADE IS EVENLY SPACED AND AT THE TRHOAT OF THE VENTURI
4. FAN MOTOR CAN BE WIRED FOR 240V OR 120V BUT THE SWITCH SUPPLIED IS 240 VOLTS ONLY. IT HAS A BUILT IN OVERLOAD.

WIRING SUGGESTION : CHECK ON LOCAL CODES

## Equipment Installation

---

*Please reference "The Chamber Plans" for more information on installation.*

**Step 1:** Place the dehumidifier at the center of the long wall with the inlet filter facing the board pile.

**Step 2:** Connect a proper length drain hose. The drain must have a trap.

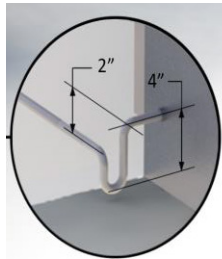

DO NOT DROP LESS THAN 4" COMING OFF UNIT, DISTANCE BETWEEN PIPES IN AND OUT OF P-TRAP MUST BE ATLEAST 2". DRAIN LINE CAN BE RUBBER PLASTIC OR COPPER TUBING.

*Note: The dehumidifier can be elevated to any reasonable amount to help the drain gravity feed. The wall opening should be sealed around where the drain hose extends outside of the chamber. Never have a floor drain.*

**Step 3:** Place the controller at a convenient point outside the chamber near the dehumidifier.

*Note: Be sure the controller is in a space that will not reach temperatures below freezing.*

**Step 4:** Remove the cover

**Step 5:** Drill 2 holes in the kiln wall to allow control cables and separately the sensor wires (inside the controller) to be carefully routed into the chamber. Do not route control and sensor wires through the same hole.

**Step 6:** Mount the Digital Sensor See "Digital Sensor Installation" on the next page.

**Step 7:** Remove the right-side panel of the dehumidifier, gaining access to the compressor and terminal strip.

**Step 8:** Securely connect the control cable to the dehumidifier.

**Step 9:** Carefully connect each wire to its corresponding terminal. Do not stretch or over-stress the cable.

*Note: Wire insulation is marked with the corresponding terminal number.*

**Step 10:** Seal the holes in the kiln wall after wires are installed to keep moisture from the control box.

**Step 11:** Install the fans over the lumber; see "Chamber Plans" as a reference.

**Step 12:** Install and caulk the vents so that they are on opposite sides of the fans and at opposite ends of the kiln.

*Note: The vents should be located as shown on the chamber drawings.*

**Step 13:** With the system switch in OFF position, connect the control box to power.

## Sensors

---

### Digital Sensor

The Digital Sensor replaces the Dry bulb and Wet bulb sensors as well as it's function on the L200 Pro Controller.

### Additional Probes

The Controller also still has 2 x PT100 probes which can be used as traditional Dry bulb and wet bulb sensors by disabling the Digital Sensor on the Advanced page of the touch screen controls

### Digital Sensor Installation

The Digital Sensor probe is mounted on the Dry bulb sensor bracket approximately 3-4 ft from the floor and roughly 6-12" from the loading door against the side wall that is closest to the control box



## L200PRO Kiln Control

---

### What is New to The L200PRO

The L200PRO takes low-temperature, small kilns to a new level. It incorporates:

- Four different operation modes, traditional DH, Hybrid DH, Heat treat, making it suitable for bug kill or other heat treat specifications and Dump cycle for getting those 8/4 and thicker slabs down from 15% to well below 10% Moisture content.
- It sports an electronic dry bulb and humidity sensor with calculated Wet bulb, as well as 2 traditional probes which can be forced (selectable) to fulfill the traditional Dry and wet bulb roles or heat treatment (when inserted into the timber) as well as setting the pitch.
- Scheduling with sample boards. Selection of average moisture content, highest or lowest sample with stop at target moisture content
- Data logging to CSV and auto email of the log file on completion
- Remote access with PC or mobile phone via VNC on the same network or access from anywhere over the Internet with port forwarding (requires set up by your local IT support)

## L200PRO Operation Modes

*L200PRO has four operation modes:*

**DH Mode:** This mode is more suitable for drying slow-drying hardwoods like oak. In this mode, the kiln is controlled according to traditional DH operation. The Wet bulb setpoint dictates when the compressor runs: Wet bulb actual > Wet bulb Setpoint = Compressor turn on. The Dry bulb controls the Heater: Dry bulb actual < Dry bulb Setpoint = Heater turns on. The vent is activated when the actual Dry bulb temperature is above the Dry bulb set point.

In this mode, using the scheduling function is optional. If not used, the user has to enter the setpoints manually. When selected, the setpoint will follow the schedule according to manually entered sample board values.

**Hybrid mode:** This mode is more suitable for faster drying species. In this mode, the kiln is controlled more according to traditional / conventional drying practice. In short, the compressor's role is changed slightly from primary moisture remover with by-product heat

to the primary heater with by-product moisture removal. The Wet-bulb temperature is controlled by venting, and the dry bulb by both the heater and the compressor. The heater will switch off at a settable DB Setpoint.

In this mode, using the scheduling function is also optional. If not used, the user has to enter the setpoints manually. When selected, the setpoint will follow the schedule according to manually entered sample board values, offset below Dry bulb set point, and the compressor will switch off at the dry-bulb setpoint.

**Heat treat mode:** In this mode, the controls look at the values of the 2 x RTD probes. When the target temperature (settable) is reached and maintained for the required time (settable), the kiln stops automatically, and a log file is emailed to the users' specified email address. This can be used for both bug kill monitoring purposes with probes inserted into the lumber OR as setting the pitch purposes with probes measuring the air temperature.

**Dump Cycle mode:** This will run a time-based Heat, dump, rest cycle with multiple repeats to get thick slabs down from 15% to 8% or less.

## Basic Operation

Whenever a value has a red border, the value can be manually edited. If a value has a grey border, it is read from either a probe or other generated input and is not editable.



When a red box is tapped or clicked, the appropriate key entry method will appear. For a value, it will be a keypad, and text, a keyboard.

For the easiest operation, connect the L200 Pro controller to your PC network, download the Real VNC Viewer and access the Kiln controller from

your Desktop PC or Laptop. Contact your local IT support for help with this.

If you don't have PC access, the screen can be accessed directly using your finger or a stylus.

## Screens

### Start-up Screen (Main Screens)

The main screen gives a brief overview of the state the kiln is in.

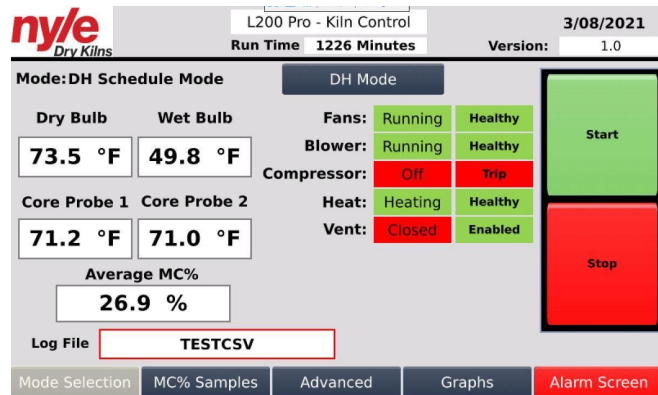

**Run Time** 1226 Minutes

**Run Time:** shows how long the kiln has run since it started.

**Mode:** DH Schedule Mode | DH Mode

**Mode:** shows in which operation mode is currently selected. In this case, the kiln is in DH DB-WB Mode. The button that appears to the right of the mode takes the user to the set point and other settings for that specific mode.

*Note: The mode can only be selected while the kiln is not running*

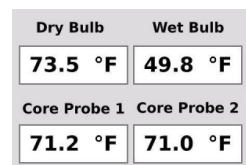

Shows the current temperature of the probes.

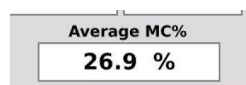

Shows the average moisture content of selected probes of samples on the MC% Samples screen.

Log File: TESTCSV

Is the CSV log file that is generated from the current run. Logs are created once per minute and recorded to this log file on the micro SD card in the controller. If no micro SD is present, no data will be recorded. The file name can be edited to be more descriptive for the user. When the kiln

is stopped, this file is emailed to the customers' specified email address on the Unit data screen if an email address is specified, and "send log files" enabled, also on the Unit data screen.

Fans:	Running	Healthy
Blower:	Running	Healthy
Compressor:	Off	Trip
Heat:	Heating	Healthy
Vent:	Closed	Enabled

This view gives a brief overview of the L200 pro's controlling element. The first column shows if the output is called or Off, and the second column gives info on whether the element is enabled and healthy. If the element is in an error state, e.g., a fan is tripped, it will show tripped. If disabled, it will show disabled. When there is an auxiliary heater present, it will also be shown below Vent.

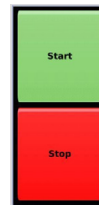

This starts and stops the kiln with selected mode and temperature



**Navigation Bar:** Each of these buttons takes the user to a screen as specified by the label on the button. When the Alarm Screen button flashes red, it means that an element is in error.

### Mode Selection

The mode selection screen is only accessible when the kiln is stopped. Selecting a mode, changes the "Mode" and "Mode button" description on the main page. The Main button will always take the user back to the main screen.

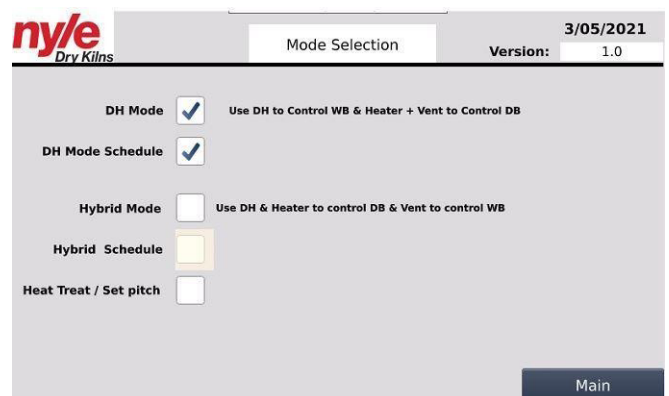

### MC% Screen

The MC% samples screen shows the selected sample values used to calculate the average mois-

ture content. If selected on the mode screen, the average moisture content is used to progress the drying process based on schedule settings. The descriptions will read Sample 1 - 8 and need to be manually entered by the user based on manually measured values of samples with a moisture meter or calculated values using the sample board method.

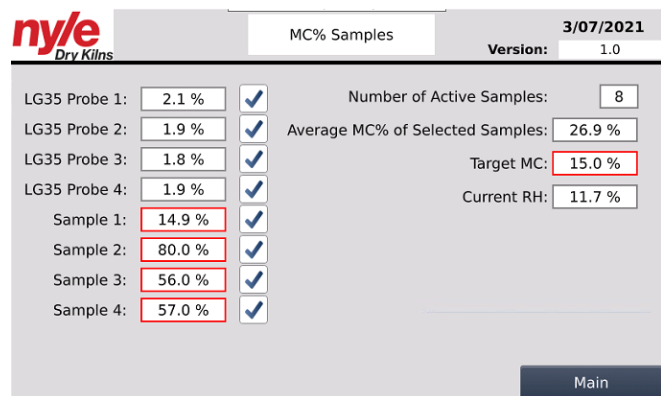

Values can be selected or deselected by tapping on the checkmark next to the value. Only selected values will be used to calculate the average moisture content. This will enable the user to control the cycle based on average moisture content, or the highest sample or lowest sample, by deselecting all but the one with the highest or lowest value.

**Target MC: 15.0 %** If the "Stop Kiln at target Moisture content" option is selected on the Advanced screen. The kiln will automatically shut off when this average moisture content is reached.

**Current RH: 11.7 %** Is read from the Electronic temperature and humidity sensor. *RH% is NOT used for control purposes.*

The timber group is used to calibrate the moisture probes according to the species being dried. This can be found in the L200 manual and needs to be set to increase the accuracy for a specific species. The most common species use the Timber group 3 setting. After setting the "New" value in the red box, click or tap on the Upgrade TG button.

## Advanced Screen

The advanced screen has multiple purposes:

- It shows the status and health and gives the option to enable and disable each element during operation mode by tapping or clicking on the toggle switch. When the switch is green



and pointing upwards, it is on or enabled, and red and down when disabled.

- When the kiln is stopped, each element can be tested by tapping or clicking on the button for that element. If the user wants to test the fans, for instance, the kiln needs to be stopped. When the user taps or clicks on the Fans button. The fans will start and run for 10 seconds.



The above options are also enabled or disabled by tapping on the corresponding toggle switch. The electronic sensor, when enabled, will use the white Digital sensor for controlling Dry bulb and Wet bulb. When disabled, the two RTD sensors will become the dry and wet bulbs, disabling the Heat treat function.

The "Stop Kiln at Target MC%" switch enables/disables this function and looks at selected samples' average moisture content value.

Tapping or clicking the Unit Data button takes you to the Unit Data Screen.



## Unit Data

The unit data screen shows user data.

- The customer name needs to be entered to show on Heat treat Graphs and the HT log files.
- The client's local IT professional needs to enter the Panel IP Address, PLC IP Address, Panel Subnet, and Panel DNS.



*Note. These entries and the Email address need to be 100% correct for the system to be able to send out Email alerts and log files when the L200 pro controller is connected to an internet-enabled network. The system is not DHCP enable and required user input.*

When "Send Log Files" is enabled, the system will automatically send out the process and HT log files when the kiln is stopped, as long as the IP settings are correct and the Internet is on.

If the Internet is off, or the kiln is not connected to a network, refer to the "accessing Data on the Controller" section on how to pull data off manually.

## Operation Modes

### DH Mode

When in DH mode, the DH Mode button will be available on the Main Screen. When the user taps or clicks on the DH mode button, the system navigates to the DH Mode screen.

Step	Start MC%	End MC%	DB SP	WB SP	Spray SP	Vent when over DB SP by
Step 1	>	45.0	90.0	88.0	0.0	1.0
Step 2	45.0	35.0	95.0	90.0	0.0	1.0
Step 3	35.0	30.0	98.0	90.0	0.0	1.0
Step 4	30.0	25.0	100.0	89.0	0.0	1.0
Step 5	25.0	20.0	110.0	88.5	0.0	1.0
Step 6	20.0	12.0	120.0	85.0	0.0	0.5

DH Mode runs the Heater to control the Heat/Dry bulb and the compressor to control the Wet-bulb. The vent is activated when the Dry bulb actual exceeds the DB SP by the offset specified in the right-hand column "Vent when over DB SP by" In this case, the controller will call for over-temperature vent when DB Probe reaches

DB SP + 1.0, or 101 as shown in the DB Over box under Current Control Values.

The DH Mode screen allows the user to enter a 6 step drying schedule based on moisture content. This is based on the drying schedules as displayed in the Nyle L200 manual. The MC% Schedule can be enabled or disabled. When Disabled, the controller will run at the setpoints under current control values. When enabled, the values from the appropriate step will automatically be written to the current control values.

The appropriate step where the current moisture content falls under is highlighted with a blue border. This is also the setpoints to which the current load is controlled.

The MC% Sample button takes the user to the MC% Sample screen and the Alarm Screen button, if visible, to the Alarms screen.

### Hybrid Schedule Mode

Step	Start MC%	End MC%	DB SP (Comp on)	Heater Offset	Vent SP	Spray SP
Step 1	>	45.0	90.0	1.0	88.0	0.0
Step 2	45.0	35.0	95.0	2.0	88.5	0.0
Step 3	35.0	30.0	100.0	2.0	90.0	0.0
Step 4	30.0	25.0	110.0	2.0	90.0	0.0
Step 5	25.0	20.0	120.0	0.0	87.5	0.0
Step 6	20.0	12.0	120.0	0.0	85.0	0.0

Hybrid mode runs the compressor as the primary call for Heat once the Dry bulb temperature is above 80 Degrees F and the Heater as the secondary call with a heater offset value. This means that if DB Probe actual is below DB SP, the compressor will be called. If the DB Probe is more than the Heater Offset value / Heater Calculated, the electric heater output will also be called.

In this mode, the Vent SP controls the WB probe value, similar to running a conventional kiln. This allows for more rapid moisture removal of quicker drying, high moisture content species like pine.

*Note: Toward the end of the drying cycle, when there is not a lot of moisture available, the WB probe value may fall to more than one degree F below Vent SP after venting. The compressor will not be called for heating as long as the WB probe exceeds the Heater Offset*

value below Vent SP. The Electric heater will be called instead. This is to prevent the condition inside the kiln from dropping too low.

The Hybrid Mode screen allows the user to enter a 6 step drying schedule based on moisture content. This is based on the drying schedules as displayed in the Nyle L200 manual. The MC% Schedule can be enabled or disabled. When Disabled, the controller will run at the setpoints under current control values. When enabled, the values from the appropriate step will automatically be written to the current control values.

The appropriate step where the current moisture content falls under is highlighted with a blue border. This is also the setpoints to which the current load is controlled.

The MC% Sample button takes the user to the MC% Sample screen and the Alarm Screen button, if visible, to the Alarms screen.

## Heat Treat Mode

Heat treat mode allows the user to run a “bug kill” or “set pitch” cycle on timber that is already dry. There is not enough energy generated by an L200 stand alone to run a heat treat or bug kill on timber with high moisture content.

Target/Set points	Actuals:
DB SP: 160.0 °F	DB Probe : 67.7 °F
WB SP: 118.0 °F <small>Kiln will Spray to reach and maintain WB SP</small>	WB Probe : 53.8 °F
Target Core Temp: 135.0 °F	Core Probe 1 : 68.0 °F
	Core Probe 2 : 67.8 °F
Minutes Set @ Target: 60	Minutes @ Target : 0

Batch # 318  
Time and Date when Condition was reached:  
File name: ht3-5-21123

**DP SP:** Is to what temperature the chamber will be heated using the Electric heater element

**WB SP:** Is the target Wet bulb temperature in the kiln. Typically, when a heat treatment is run, timber will dry out further. To prevent this, the user can read the corresponding Wet bulb value for the Dry bulb setting from the Psychrometric tables in the manual to determine the correct wet bulb setting. E.g., If target MC is 8%, the EMC in the kiln should not be allowed to go below 8%. For 140oF DB, the corresponding WB will be 118°F. The spray will come on to raise the WB Probe value to 118.

Note: A spray line should be installed, and Spray should be enabled in the Advanced screen

Target Core temperature is the minimum temperature at which both RTD probes must be to enable a time and date stamp when the condition was met and start the Minutes at the target temperature counter.

At the start of each batch, the batch number is automatically incremented. The kiln stops automatically when the 2 core RTD probes are above the Target Core temperature for as long as specified in the “Minutes Set @ Target” box.

In this example, the kiln would automatically stop when both core probes were above the “Target Core Temp” of 135 F for more than 60 Minutes. When the kiln stops, the log file with “Filename” specified is emailed to the user’s specified email address, provided IP settings are correct, and the controller is on an internet-enabled network.

The graph button takes the user to heat treatment-specific graphs.

This function can also be used for setting pitch. The only difference is that the two RTD probes should be left on their brackets measuring air temperature instead of inserted into the lumber.

Note: The time and temperature example above were only for testing logic. The user should apply their local country or region specifications when running a bug kill or set pitch cycle.

## Dump Cycle Mode

Target/Set points	Actuals:
DB SP: 160.0 °F	DB Probe : 67.7 °F
WB SP: 118.0 °F <small>Kiln will Spray to reach and maintain WB SP</small>	WB Probe : 53.8 °F
Target Core Temp: 135.0 °F	Core Probe 1 : 68.0 °F
	Core Probe 2 : 67.8 °F
Minutes Set @ Target: 60	Minutes @ Target : 0

Batch # 318  
Time and Date when Condition was reached:  
File name: ht3-5-21123

Dump cycle mode is designed to remove the last bit of “stubborn” moisture from thick lumber. It is a simple operation of Heating to a temperature for a period, then venting for a period, then switching all off and resting for a period. This forces the

moisture from the core to migrate to the surface, following the heat energy as the load cools down. The number of times the cycle is repeated can be set by setting the repeat cycle value. One would typically heat for 24 hours, then vent for 10-15 minutes, then let the load rest for 12-24 hours before repeating the cycle.

## Equalizing & Conditioning

Seeing as equalizing and conditioning is such a critical step, it is best to run it manually. The best way to do it is to stop the kiln and select DH Mode with the MC% Schedule Enable NOT checked.



Enter the target Dry bulb Set, Wet bulb, and Spray set points from DH mode. Note that the compressor will not run above 122 °F, so the WB SP is actually not relevant. It should be set to be equal to your Dry bulb set point (DB SP)

Use the Psychrometric charts in the manual to calculate the desired EMC or RH% you want to run the kiln at. Set the DB SP and Spray SP accordingly.

E.g., If you wanted to equalize at 8% EMC / 51% RH at 140 °F. The lookup on the Psychrometric chart points to 118°F for the Wet-bulb. The electric heater will heat the chamber to get to DB SP, while Spray will come on to raise and maintain the WB temperature to Spray SP

*Note: A spray line should be installed, and Spray should be enabled in the Advanced screen*

## Graphs

### Process Graphs

Process graphs can be viewed by clicking or tapping on the Graphs button on the main screen.

The current graph views available are 3 hours and 96 hours. Values on these graphs are stored on the micro SD card once a second, and the user can zoom in on a specific reading or line by stopping the graph and tapping or clicking on the appropriate line.

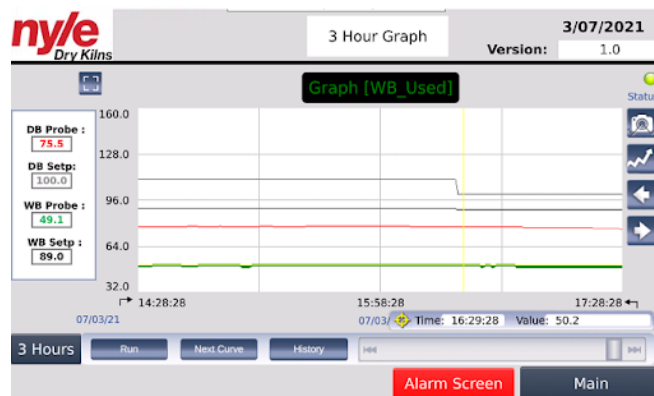

For more info, see the KilnIQ Video on Youtube: "Introducing the L200PRO Controls."

### HT Graph

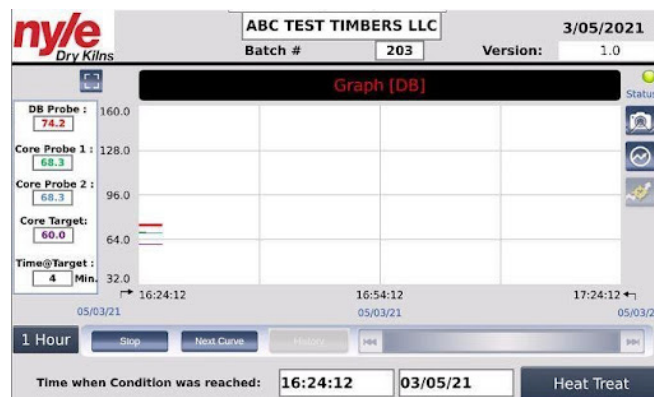

The HT Graph shows the probe values, time and date when Set conditions were met, batch number as well as time how long conditions were met. The view is available in 1 hour, 2 hours, and 6 hours by clicking or tapping on the hour button on the bottom left of the screen.

### Saving a Graph

The graphs can be saved by tap and holding down in the top right-hand corner of the screen. A dialog box will appear prompting the following:



An option appears to name the file by clicking or tapping Screenshot; the current graph is saved as a .jpg file in the screenshots folder on the micros SD card.

# Alarming

Whenever an alarm is active, there will be a red alarm button flashing on the current screen. Tapping or clicking on it will take the user to the alarm screen.

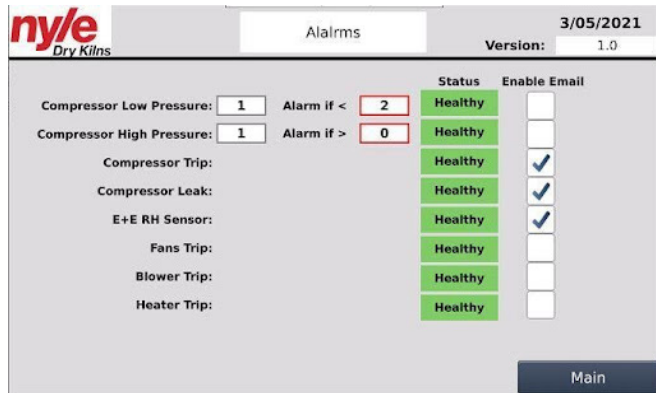

The alarm screen has eight alarm conditions that are being monitored. It also gives the user an option to enable the “sent email when the alarm is active.” When this option is selected, the alarm name and basic description of the possible cause will be emailed to the user email address specified on the Unit Data page

- **Compressor Low Pressure:** This is only a notification and will not disable the kiln. It will have a preset value. If this value is low, it could indicate a leak in the refrigeration system.
- **Compressor High Pressure:** This is only a notification and will not disable the kiln. It will have a preset value. If this value is high, it could indicate that the kiln is running too high for the compressor to operate.
- **Compressor Trip:** This is a critical error but will not disable the kiln. This alarm is activated when the compressor is called, but the high pressure stays low. This requires that the L200 base unit be opened and the high-pressure switch be reset. If the problem persists, call Nyle support.
- **Compressor Leak:** This is a critical error but will not disable the kiln. If this Alarm comes on, the Low pressure is way below minimum pressure and is a definite indicator that there is a leak in the refrigeration system. Call Nyle Support
- **Digital RH Sensor:** This is a critical error and could indicate that the PLC controller has lost communication with the sensors or that the

value has remained constant for more than an hour, indicating a faulty probe. Check the cables. If the error does not go away, the user can disable the “Electronic Sensor” on the Advanced screen. This will disable heat treat mode and turn the additional RTD probes into the controlling wet (Probe 2) and dry bulb (probe 1)

- **Fans Trip:** This is not a critical error but requires immediate action. The user needs to open the control panel and check and reset the mechanical overload that tripped. If it trips again, it is an indicator that the specific fan motor is busy failing. The fan should be blocked off if it cannot be removed with a full load and taken to an electric armature winding shop for testing if out of warranty or sent back to Nyle to be tested and replaced under warranty.
- **Blower Trip:** This is a critical error and will disable the heater and the compressor. The user needs to open the control panel and check and reset the mechanical overload that tripped. If it trips again, it is an indicator that the specific fan motor is busy failing. The fan should be blocked off if it cannot be removed with a full load and taken to an electric armature winding shop for testing if out of warranty or sent back to Nyle to be tested and replaced under warranty.
- **Heater Trip:** The heater trip is a “soft” trip that cannot be reset. It is a thermistor that trips when the unit gets too hot. It will reset automatically when the unit cools down. If not does not reset automatically, call Nyle support.

## Accessing Data on The Controller

Log files and graph screenshots can be accessed and copied to a USB thumb drive if and when required by entering UniApps mode on the controller. The steps below must also be followed to clean the memory on the Micro SD card from time to time.

UniApps is a built-in function that allows the user access to a file manager and other functions like setting the time and time zone on the controller. These will be the only two functions this manual will

*Note. Other functions available in Uniapps are advanced, and users should not attempt to change anything else but the time and copy files to a thumb drive.*



To enter UniApps, tap or click and hold on the top right hand corner of the screen.



Tap or click on the UniApps button. This opens the main UniApps screen.



This manual will only deal with setting the time from the time & Date icon and file transfer that is on the "Memory" tab.

These functions all work very similarly to a Windows-based PC.

## Setting Date & Time



To set the time and date, tap or click on the Time & Date icon and set the items you wish. Each time OK is clicked or tapped, the changed value is saved.

## Transferring Files to USB



To access the files on the MicroSD card, tap on the Memory tab at the bottom of the screen.

Next, tap on the File Browser Icon.

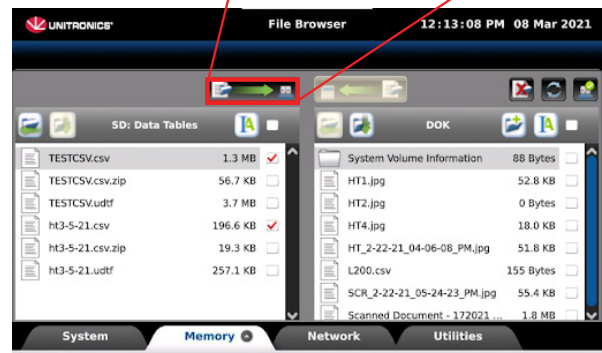

If there is a readable USB drive plugged into the USB port on the controller, the File Browser view will show the contents on the SD card on the left pane and the contents of the USB drive on the right pane. The recorded CSV log files are situated in the Data Tables Folder on the left. All graph screenshots are located in the "Screenshots" folder. To send files from the SD card, tap on the folder containing the files you want to send. And select the files you wish to send. The moment files are selected, the icon that allows the transfer to happen becomes available

When the user taps this icon, a prompt will appear with the options "OK" to continue or "Cancel" to stop.



To remove the USB drive, tap on the Safe to remove USB icon in the top right-hand corner of the screen. A prompt will appear asking "Eject OK," tap OK to remove safely.

To exit and return to the Kiln program, tap and hold the top right-hand corner of the screen and select UserApp.

# Drying Lumber

*Nyle recommends that these guidelines be followed carefully.*

## Placing Stickers and Loading Lumber

- Stickers should all be at least  $\frac{3}{4}$ " thick and all sticks in any load must be the same thickness.
- Thick lumber (10/4" and thicker) should be dried using double stickers.
- End stickers should be as close to the ends of the boards as possible.
- The sticker spacing should be approximately 18". This spacing can be reduced to 12" if excessive warping, cupping, and bowing are a problem.
- Keep stickers in a vertical line and always support the load under each sticker.
- If you have some wide boards, or other pieces that you want to keep as straight as possible, pile them on the bottom as the weight of the lumber above will constrain the wide boards and give the best result.
- If a less than full load is anticipated, it is better to reduce the depth rather than the height or width. This will obviously leave the stickers "hanging out", but will result in better drying.

## Ensuring Proper Airflow

- When the lumber is fully loaded, the baffles should be lowered to the top of the lumber and the side baffles should be carefully positioned. If no side baffles are installed, the space could be closed off with plywood or boards.
- Never use plastic sheeting as it may come loose and become entangled in the fans.
- If the load supports are thicker than normal stickers, the extra space should be blocked with a narrow board or lath.
- Close off any large openings that will let air go around the lumber. Air will take the path of least resistance, and you must force it through the stickered pile.
- A small amount of time spent doing this correctly will result in more even, faster, and less expensive drying.

## Drying Schedules

Each species of lumber has a maximum rate of drying (expressed as % loss/day) that can be tolerated without damage. These rates have been determined through experimentation by the U.S. Dept. of Agriculture, various universities and others. Schedules have been developed based on time, dry bulb-wet bulb temperatures, and even automatic moisture content devices. Due to the many important variables that affect drying such as kiln chamber heat loss, air velocity, ambient temperature and humidities, vapor leaks, etc., the most important consideration of a schedule is that you maintain a safe drying rate.

The L200 drying system dries lumber by using the dry bulb and wet bulb temperatures of the kiln to control the operation of the dehumidifier. The schedules on page 20 are based on dry bulb and wet bulb conditions (humidity). These schedules are starting points; you will probably change these over time because you will find different settings work for you. This is due to the fact that different people saw boards differently, stack lumber differently, build chambers differently, etc.

If the dry bulb temperature is above 80°F, and the wet bulb is 2°F above its set point, (factory setting) the compressor will turn on. When the compressor is on, moisture is being condensed on the cold coil in the unit, and draining away. This moisture being removed reduces the humidity, dropping the wet bulb temperature.

The moisture removal rates on page 27 are the rates to follow when first using the machine. These rates can be safely exceeded by an additional 50% (i.e., 1.0% can be raised to 1.5% and 3.3% can be increased to almost 5%) given careful judgment and operating experience for Groups 1, 2, and 3. Top quality moisture meters, or weight samples, must be used at these higher drying levels to avoid lumber damage. Some hardwoods such as Southern Red Oak, White Oak, and Group 4 hardwoods should not use any sort of accelerated schedule.

## Wood Groups

*Note: When drying a mixed load of woods, colored wood (ie Red Oak) must be stacked on the bottom to prevent the moisture from it staining the other wood.*

Group 1 (L200 load size, 1500 BF, 3.5m <sup>3</sup> )
4/4 Softwoods
4/4 Soft Hardwoods
Group 2 (L200 load size, 3000 BF, 7m <sup>3</sup> )
4/4 Medium Hardwoods
8/4 Softwoods
8/4 Soft Hardwoods
Group 3 (L200 load size, 4000 BF, 9m <sup>3</sup> )
4/4 Hardwoods
8/4 Medium Hardwoods
Group 4
8/4 Hardwoods

## Lumber Types

Softwood			
Cedar, Eastern White	Pine, Red (Norway)	Spruce, White	
Fir, Balsam	Pine, Eastern White		
Hemlock, Eastern	Spruce, Black		
Larch, Eastern	Spruce, Red		
Soft Hardwoods			
Aspen			
Basswood			
Cottonwood			
Poplar			
Medium Hardwood			
Ash, Black	Birch, Yellow	Maple, Soft	Walnut
Ash, White	Cherry, Black	Maple, Hard	
Beech	Elm, White	Sweet gum (Red gum)	
Birch, White	Hickory	Tupelo (Black gum)	
Hardwoods			
Elm, Rock			
Oak, Red			
Oak, White			

## Moisture Removal Rates

### *Moisture Removal Rate Per Day (Maximum)*

These removal rates are estimates only. Always check your actual removal rates daily, using an accurate moisture meter. There are many variables that affect drying rates, such as how lumber is sawn, stacked, and how the chamber is built.

The following chart shows the calculated moisture removal rate per 24 hour period for an L200 Running at 100% .

Load Size	Group 1	Group 2	Group 3
1000 BF	13.7%	9.3%	8.5%
1500 BF	9.0%	6.2%	5.7%
2000 BF	6.7%	4.6%	4.3%
2500 BF	5.4%	3.7%	3.4%
3000 BF	4.5%	3.1%	2.8%
3500 BF	3.9%	2.6%	2.4%
4000 BF	3.4%	2.3%	2.1%

*\*Drying rate may be too high, look at the maximum rates.*

Drying Group 1 woods at a rate of less than 5% per day may result in mold or staining of the lumber.

Drying Group 3 woods at a rate greater than 3.5% per day may result in checking or other degrade to the lumber.

## L200 Drying Schedules

Moisture Content	Normal Schedule		Alternate Schedule	
	Dry Bulb	Wet Bulb	Dry Bulb	Wet Bulb
<b>Group 2</b>				
Above 45%	90° F	85° F	100° F	97° F
45% - 35%	100° F	87° F	105° F	93° F
35% - 25%	110° F	96° F	110° F	96° F
25% - Final	120° F	90° F	120° F	90° F
<b>Group 3</b>				
Above 45%	90° F	86° F	100° F	97° F
45% - 35%	100° F	96° F	105° F	101° F
35% - 25%	110° F	98° F	110° F	98° F
25% - Final	120° F	98° F	120° F	98° F
<b>Group 4</b>				
Above 50%	90° F	85° F	100° F	97° F
50% - 40%	95° F	89° F	100° F	96° F
40% - 35%	100° F	90° F	105° F	97° F
35% - 30%	110° F	98° F	110° F	98° F
30% - Final	120° F	95° F	120° F	95° F

Group 1 woods generally do not have a maximum drying rate, you will want to remove the moisture quickly, and fast enough to avoid mold and stain. Set the Dry Bulb on 120°/Wet Bulb at 75°. The compressor will run constantly. You can turn the heat switch off once the temperature reaches 100°, Heat from the compressor motor and fan motors will keep the temperature rising. (At the end of the drying cycle, for softwoods, turn the compressor switch "OFF", and set the dry bulb temperature to 150° F. or 160° F. to set pitch.)

*Use the alternate schedules if you are in a warm climate or otherwise unable to maintain a 90° F dry bulb temperature at the beginning of the drying cycle.*



## Drying Rates (North American Measure)

Species	Oven Dry Weight #/MBF	Avg. Green MC %	Green Weight #/MBF	# Water Per % MC	Max MC% Loss/ day
Cedar, Eastern White	1578	93	3046	16	11
Fir, Balsam	1739	118	3790	17	20
Hemlock, Eastern	2161	111	4558	22	20
Larch, Eastern	2532	52	3849	25	20
Pine, Red (Norway)	2051	83	3747	21	15
Pine, Eastern White	1950	90	3705	20	12
Spruce, Black	2110	80	3798	21	20
Spruce, Red	2000	89	3781	20	20
Spruce, White	1840	115	3967	18	20
Ash, Black	2532	95	4937	25	7
Ash, White	3055	45	4431	31	10.4
Basswood	1899	107	3933	19	12
Beech	3114	63	5089	31	4.5
Birch, White	2692	73	4659	27	10
Birch, Yellow	2954	69	4996	30	6.1
Cherry, Black	2633	58	4161	26	5.8
Elm, Rock	3165	50	4760	32	3.5
Elm, White	2692	93	5207	27	10.4
Hickory	3325	64	5452	33	6
Maple, Soft	2692	93	4389	27	13.8
Maple, Hard	3165	68	5317	32	6.5
Oak, Northern Red Upland	3277	74	5703	33	3.8
Oak, White Upland	3518	70	5981	35	2.5
Oak, Southern Red	3092	80	5567	31	3.8
Sweetgum (Red gum)	2740	100	5480	27	5.3
Walnut	2851	85	5274	29	8.2
Yellow Poplar, Cottonwood	1899	154	4819	19	13.8

Northeast Lumber - Based on 4/4 (1" or 25 mm)

To estimate maximum % MC loss per day for other thickness' multiply % MC loss per day from the above table by 0.6 for 6/4 and 0.4 for 8/4.

## Drying Rates (Metric)

Species	Oven Dry Weight Kg / M3	Avg. Green MC %	Green Weight Kg / M3	Kg Water Per % MC	Max MC% Loss/day
Cedar, Eastern White	315.6	93	609.2	7.27	11
Fir, Balsam	347.8	118	758	7.73	20
Hemlock, Eastern	432.2	111	911.6	10	20
Larch, Eastern	506.4	52	769.8	11.36	20
Pine, Red (Norway)	410.2	83	749.4	9.55	15
Pine, Eastern White	390	90	741	9.09	12
Spruce, Black	422	80	759.6	9.55	20
Spruce, Red	400	89	756.2	9.09	20
Spruce, White	368	115	793.4	8.18	20
Ash, Black	506.4	95	987.4	11.36	7
Ash, White	611	45	886.2	14.09	10.4
Basswood	379.8	107	786.6	8.64	12
Beech	622.8	63	1017.8	14.09	4.5
Birch, White	538.4	73	931.8	12.27	10
Birch, Yellow	590.8	69	999.2	13.64	6.1
Cherry, Black	526.6	58	832.2	11.82	5.8
Elm, Rock	633	50	952	14.55	3.5
Elm, White	538.4	93	1041.4	12.27	10
Hickory	655	64	1090.4	15	6
Maple, Soft	538.4	93	877.8	12.27	13.8
Maple, Hard	633	68	1063.4	14.55	6.5
Oak, Northern Red Upland	655.4	74	1140.6	15	3.8
Oak, White Upland	703.6	70	1196.2	15.91	2.5
Oak, Southern Red	618.4	80	1113.4	14.09	2
Sweetgum (Red gum)	548	100	1096	12.27	5.3
Walnut	570.2	85	1054.8	13.18	8.2
Yellow Poplar, Cottonwood	379.8	154	963.8	8.64	13.8

Northeast Lumber - Based on 4/4 (1" or 25 mm)

To estimate maximum % MC loss per day for other thickness' multiply % MC loss per day from the above table by 0.6 for 6/4 and 0.4 for 8/4.

## Kiln Sample Boards

It is best to use sample boards to measure moisture content on a daily basis. Moisture meters are not accurate enough for most hardwood dry kiln operations when the wood is above 30% MC and there is a need to keep a close watch on the drying rate. In Oak, for example, all checks and honeycombing occur when the wood is drying from green down to 40% MC, so that is when the drying rate needs to be closely controlled.

### Uses for Sample Boards

- To estimate the MC of the load in the chamber, so that kiln conditions can be regulated according to drying schedules.
- To measure the drying rate, which allows control of drying quality.
- To check on any degrade development.
- To check on final MC and drying stresses.
- To develop a MC vs. time curve.
- To study variations in drying within the kiln.
- To monitor changes in MC after drying (during storage and shipping) Note: It is a good idea to keep sample boards with dried lumber so that they can be used to track moisture content changes in storage.

### Taking Samples

1. Select sample boards. Keep in mind that they need to represent a "sample" of the lumber in the kiln. Do not select junk boards, and select both the slowest and the fastest drying boards of the load. Generally, you want six sample boards.
2. Cut 30" samples, at least 12" from the ends of each of the sample boards. Avoid having knots, splinters or bark in the sample.
3. Number the samples you cut.
4. Cut two 1" sections off each end of the samples, and mark them with the number of the board they came from.

*Example: the two sections that came from sample board 3 would be labeled 3A and 3B.*

5. Apply end coat to the 28" sample boards. This assures that the sample board will dry as though it were a larger piece of lumber.

End coatings are not usually required when lumber is placed in the kiln directly after being sawn. However when lumber is air dried prior to kiln drying, end coating is often helpful in preventing end checks

6. Weigh the 28" sample boards. An accuracy of .025 pounds or 1 gram is recommended. Record these values.
7. Put the 28" sample boards in the lumber stacks in places where they can be reached and will dry at the same rate as the lumber. Do not place the sample boards where they will receive more air flow than the rest of the lumber.
8. Take the "green weight" by weighing all the 1" sections, to 0.1 gram accuracy is suggested. Record these values.
9. Oven dry the 1" sections using one of the two methods below.
  - Microwave with carousel tray: Put sections on a paper towel on the tray. Use low power (to avoid smoking) for 20 minutes. Weigh the section, and put back in the microwave for 1 minute. If the section has not lost any weight, it is oven dry. If still losing water, continue drying in 5 minute increments until a constant weight is achieved.
  - Oven: Place the 1" section in an oven at 215°F (101°C) until the section stops losing weight, usually takes 24 hours. Check hourly until the section weighs the same in separate weighings.
10. Calculate the moisture content of each 1" section separately using the following formula:
11. Average the moisture content of the two 1" sections from each 28" sample board to calculate the estimated moisture content of the sample board when it was cut.
12. Calculate the oven dry weight of the 28" sample board is using the following formula and the average moisture content (MC) from the previous step:
$$\text{OD weight} = \left( \frac{\text{Wet Weight}}{100 + \%MC} \right) \times 100$$
13. Write the calculated OD weight on the sample board so that it is readily available.

14. At about the same time each day, weigh the sample boards and calculate the current moisture content with this formula:

$$\text{Current \%MC} = \left( \frac{\text{Current Weight}}{\text{Calculated Oven Dry Weight}} - 1 \right) \times 100$$

15. Place the 28" sample board back in the same place in the kiln it came from.
16. Calculate the daily drying rate for each section. Keep all the figures written down as a record of the load. Make any adjustments to the schedule based on the fastest drying sample.
17. Once the moisture content of the kiln is below 20%, it is often a good idea to cut new 1" sections from the center of the sample boards (1 section per board).

Example: Two 1" sections are cut from 30" sample board 1, and labeled 1A and 1B. They are weighed on a balance, and the weights are: A=2.5g and B=2.3g. The sections are placed in a microwave on low power for 20 minutes and weighed, weighing A=1.7g and B=1.6g. They are put back in the microwave for 1 minute and weighed again. The weights did not change, so these values are now oven dry weights.

- Calculate the moisture content using the formula in step 10.  
 $A = [(2.5 / 1.7) - 1] \times 100 = 47.06$   
 $B = [(2.3 / 1.6) - 1] \times 100 = 43.75$
- Average the two calculations together:  
 $(47.06 + 43.75) / 2 = 45.40\%$   
 This is the calculated moisture content for the rest of the sample board.
- Calculate the oven dry weight of the sample board 1. Use the formula in step 11. The green weight is 1.64 kilograms.  
 $ODW = (1.64 / 145.4) \times 100 = 1.13 \text{ kg}$
- After a day in the kiln, weigh sample board 1 and it weights 1.58 kg. Using the formula in step 13, the moisture content is:  
 $\%MC = [(1.58 / 1.13) - 1] \times 100 = 39.8$
- The daily change in moisture content is:  
 $45.4 - 39.8 = 5.6\%$

## Record Keeping

A good system of record keeping for the dry

kiln is essential to developing a good operating procedure. The records that are kept will indicate when operations are deviating from the norm and will allow future schedules to alter to improve production.

*Note: It is recommended that all information be kept on the sample boards as outlined in the Dry Kiln Operator's Manual.*

In addition to the records kept daily on the sample boards, it is also very important to plot on a graph the average and wettest drying sample. If possible, plot all the samples on the graph. This will indicate the drying rate and often any adjustment will become apparent on the graph before it is analyzed in the data.

Each day, the water removal should be weighed for one minute and that figure recorded on the kiln records. While one direct use is made of this information in the drying schedule, a deviation from normally expected water flows will give early warning of a malfunction in the refrigeration system.

Several times during the cycle the bulb should be measured on both sides of the load and in several areas. The average should be noted on the kiln record. As with measuring the water removal rate, this is not used in the operation of the kiln but deviations from normal will indicate a problem in loading, baffling, airflow etc. That will affect drying. These figures will always vary but being familiar with them, the operator will be able to detect a malfunction early.

Record should be kept for comparison throughout the year. It is wise to compare summer loads with summer and winter loads.

## Drying Rate Index (DRI)

The dry kiln industry has never had a method of predicting drying rates. This is remarkable as one main reason for having a kiln is to bring about predictable production rates. The EMC value gives an end point of what the moisture content of the lumber would eventually become but it does not give an indication of how long it will take to reach that moisture content.

Drying schedules for dehumidification drying were developed in the late 1970's. It became obvious that a method of adjusting kiln schedules to meet drying time objectives within the limitations

of the operation range of the dehumidifiers had to be found. It was common to look up a drying schedule in the Dry Kiln Operators Manual or some other reference, and then find a set of conditions at which dehumidifier could run using the same EMC. This resulted in unnecessarily long drying cycles and was quickly shown to be an ineffective method of doing kiln schedules.

Nyle developed the Drying Rate Index in response to that but time has shown that the Drying Rate Index is very useful in both conventional and dehumidification kilns. With the trend to control kilns by monitoring drying rate to get maximum productivity and quality, the Drying Index becomes a very valuable tool.

The drying rate is a function of the vapor pressure deficit. Everyone knows that things dry faster in hotter, drier air. Every fluid has a vapor pressure associated with it that varies with the temperature of the fluid. Air has a vapor pressure that is of function of temperature and humidity. The difference between the two determines the rate drying. This is how everything in the world dries whether it is paint, the ocean, the lumber or perspiration. When the humidity of the air is 100% no evaporation takes place regardless of the temperature. As relative humidity drops the rate the fluid evaporates increases. The problem is that a way of predicting the change in drying rate with changes in temperature and humidity was needed.

### The Drying Rate Index is a relative number.

*Example: A kiln is operating at 120° F. dry bulb and 110° F. wet bulb, that means the depression is:*

10° (120° F.- 110° F. = 10° F.) According to the Nyle Drying Chart, The relative humidity is 72% the Equilibrium Moisture Content (EMC) is 12.1% and the Drying Rate Index (DRI) is 1.0. The EMC indicates where the lumber will end eventually. The EMC is also an indication of where the surface moisture content of the lumber will go fairly quickly. The whole board will eventually be 12.1 % but the surface will reach 12.1% much quicker.

In the above example, the lumber might be drying at 3% per day but it could be dried faster at 5% per day. In order to change the drying rate from 3% per day to 5% per day, it would be necessary to find a DRI that is 1.67 times the existing drying rate.

Desired Drying Rate/Existing Drying Rate = Multiplier.  
(5/3=1.67)

Multiplier x Existing DRI= Desired DRI

The existing DRI is 0.9 so the new DRI should be 1.5  
(0.9 x 1.67)

Referring to the Nyle Drying Chart (Pg 27), it can be seen that if the temperature were increased to 130° F and the depression 13° F (read between 12 and 14 on the chart), the DRI will be 1.5. Other combinations of dry bulb and depression will give the same result.

*Example: Dry bulb could be left at 120° F and the depression increased to 17° F, or the dry bulb could be raised to 140° F. and the depression left at 10° F. All of these would result in a 1.5 DRI and thus would dry the lumber at 5% per day.*

*Note: The above three choices, 130/13, 120/17 and 140/10, the EMC is 10.5, 9.1 and 11.9 respectively. It is clear that EMC has nothing to do with how fast lumber dries but it does mean that low temperatures and bigger depressions may mean the surface moisture content will be lower. In some cases, were this pressed to an extreme, it may make the surface shrink too much so that factor should be considered.*

The best way to use the drying chart is to check the kiln each day. Calculate the moisture loss and then adjust the kiln temperature and humidity each day to achieve the drying rate desired. Each charge of lumber will be different and will result in a different drying schedule. For this reason, it will be clear that drying schedules are of little use except as a starting point. None of the drying schedule published state at what airflow they were developed. So running a schedule from a manual or another operation is ineffective as the airflow in the kiln may be different and may change through the cycle if variable speed fans are used.

### Drying Tips

- Fresh cut lumber dries better and is less likely to be damaged during the drying process. Try to get it in the kiln as soon as possible.
- If you can't dry your lumber immediately after its been cut make sure that it is stacked, stickered and stored in a clean, dry place. Monitor it until it is ready to be put in the kiln as its moisture content will change during this time.

- Carefully plan your drying schedules for every batch of lumber and follow through with them, only making alterations when necessary. Neglecting an effective schedule can ruin product and cost you money.
- Air flowing through the lumber will be removing the moisture. Make sure you take the time to properly sticker and stack your lumber in the kiln. Better airflow will result in better drying.
- Use baffles and deflectors to control airflow inside the kiln when drying, it will be more efficient and result in more evenly dried lumber.
- Keep detailed records of every batch. If necessary you can use them as a reference when making improvements in scheduling or correcting mistakes.
- Make sure that an operator is always available when drying so that any necessary adjustments can be made as soon as possible. This will reduce the chance of any major issues during the process.
- Always double check your numbers at the end of a schedule to make sure that you have achieved your desired result.
- Every detail is important when drying lumber. Make sure that you are following operation and safety guidelines. Cutting corners can ruin your product, damage your unit, or even cause injury.
- If you are unsure about any aspect of operation or if something seems to be working incorrectly please contact Nyle as soon as possible.

*Do not continue operation, attempt any adjustment or repair to a unit with out consulting a licensed professional.*

- Once a batch of lumber is dried keep it in a clean, dry location, away from the elements. Ideally kept inside and off the ground.
- Always stay up to date with the latest information on lumber drying. Attend trainings and seminars whenever possible and keep in contact with your local forestry offices



# Nyle Drying Chart

Wet Bulb Depression [Dry Bulb - Wet Bulb] °F

Dry Bulb °F	Measurement	2°	4°	6°	8°	10°	12°	14°	16°	18°	20°	25°	30°	35°	40°	45°	50°
30°	RH	78.0	57.0	36.0	17.0												
	EMC	15.9	10.8	7.4	3.9												
	DRI	0.0	0.1	0.1	0.1												
35°	RH	81.0	63.0	45.0	28.0	11.0											
	EMC	16.8	11.9	8.8	6.0	2.9											
	DRI	0.0	0.1	0.1	0.1	0.2											
40°	RH	83.0	68.0	52.0	37.0	22.0	8.0										
	EMC	17.6	12.9	9.9	7.4	5.0	1.9										
	DRI	0.0	0.1	0.1	0.2	0.2	0.2										
45°	RH	85.0	72.0	58.0	44.0	31.0	19.0	6.0									
	EMC	18.3	13.7	10.7	8.5	6.5	4.2	1.5									
	DRI	0.0	0.1	0.1	0.2	0.2	0.2	0.3									
50°	RH	86.0	74.0	62.0	50.0	38.0	27.0	16.0	5.0								
	EMC	19.0	14.4	11.5	9.4	7.6	5.7	3.9	1.5								
	DRI	0.1	0.1	0.1	0.2	0.2	0.3	0.3	0.3								
55°	RH	88.0	76.0	65.0	54.0	44.0	34.0	24.0	14.0	5.0							
	EMC	19.5	15.1	12.2	10.1	8.4	6.8	7.3	3.6	1.3							
	DRI	0.1	0.1	0.2	0.2	0.2	0.3	0.3	0.4	0.4							
60°	RH	89.0	78.0	68.0	58.0	48.0	39.0	30.0	21.0	13.0	5.0						
	EMC	19.9	15.6	12.7	10.7	9.1	7.6	6.3	4.9	3.2	1.3						
	DRI	0.1	0.1	0.2	0.2	0.3	0.3	0.4	0.5	0.5	0.5						
65°	RH	90.0	80.0	70.0	61.0	52.0	44.0	36.0	27.0	20.0	13.0						
	EMC	20.3	16.1	13.3	11.2	9.7	8.3	7.1	5.8	4.5	3.0						
	DRI	0.1	0.1	0.2	0.2	0.3	0.3	0.4	0.5	0.5	0.5						
70°	RH	90.0	81.0	72.0	64.0	55.0	48.0	40.0	33.0	25.0	19.0	3.0					
	EMC	20.6	16.5	13.2	11.6	10.1	8.8	7.7	6.6	5.5	4.3	0.7					
	DRI	0.1	0.1	0.2	0.3	0.3	0.4	0.4	0.5	0.6	0.6	0.7					
75°	RH	91.0	82.0	74.0	66.0	58.0	51.0	44.0	37.0	31.0	24.0	10.0					
	EMC	20.6	16.8	14.0	12.0	10.5	9.3	8.2	7.2	6.2	5.1	2.3					
	DRI	0.1	0.2	0.2	0.3	0.4	0.4	0.5	0.6	0.6	0.7	0.8					
80°	RH	91.0	83.0	75.0	68.0	61.0	54.0	47.0	41.0	35.0	29.0	15.0	3.0				
	EMC	21.0	17.0	14.3	12.3	10.9	9.7	8.6	7.7	6.8	5.8	3.5	0.3				
	DRI	0.1	0.2	0.3	0.3	0.4	0.5	0.5	0.6	0.7	0.7	0.9	1.0				
85°	RH	92.0	84.0	76.0	70.0	63.0	56.0	50.0	44.0	38.0	33.0	20.0	9.0				
	EMC	21.2	17.2	14.5	12.5	11.2	10.0	9.0	8.1	7.2	6.3	4.3	1.7				
	DRI	0.1	0.2	0.3	0.4	0.4	0.5	0.6	0.7	0.8	0.8	1.0	1.1				
90°	RH	92.0	85.0	78.0	71.0	65.0	58.0	52.0	47.0	41.0	36.0	24.0	13.0	3.0			
	EMC	21.3	17.3	14.7	12.8	11.4	10.2	9.3	8.4	7.6	6.8	4.9	2.8	0.9			
	DRI	0.1	0.2	0.3	0.4	0.5	0.6	0.7	0.8	0.8	0.9	1.1	1.2	1.4			
95°	RH	92.0	85.0	79.0	72.0	66.0	60.0	55.0	49.0	44.0	39.0	28.0	17.0	8.0			
	EMC	21.3	17.4	14.9	12.9	11.6	10.5	9.5	8.7	7.9	7.1	5.3	3.6	1.9			
	DRI	0.1	0.2	0.3	0.5	0.6	0.7	0.7	0.8	0.9	1.0	1.2	1.4	1.5			
100°	RH	93.0	86.0	80.0	73.0	68.0	62.0	56.0	51.0	46.0	41.0	30.0	21.0	12.0	4.0		
	EMC	21.3	17.5	15.0	13.1	11.8	10.6	9.6	8.9	8.1	7.4	5.7	4.2	2.8	0.7		
	DRI	0.1	0.3	0.4	0.5	0.6	0.7	0.9	0.9	1.0	1.1	1.4	1.5	1.7	1.9		



105°	RH	93.0	87.0	80.0	74.0	69.0	63.0	58.0	53.0	48.0	44.0	34.0	24.0	16.0	8.0		
	EMC	21.4	17.5	15.1	13.2	11.9	10.8	9.8	9.0	8.3	7.6	6.1	4.6	3.3	1.8		
	DRI	0.2	0.3	0.4	0.6	0.7	0.8	0.9	1.1	1.2	1.3	1.5	1.7	1.9	2.1		
110°	RH	93.0	87.0	81.0	75.0	70.0	65.0	60.0	55.0	50.0	46.0	36.0	26.0	19.0	11.0	4.0	
	EMC	21.4	17.5	15.1	13.3	12.0	10.8	9.9	9.2	8.4	7.7	6.3	4.8	3.8	2.5	1.1	
	DRI	0.2	0.3	0.5	0.6	0.8	0.9	1.0	1.2	1.3	1.4	1.7	1.9	2.1	2.3	2.5	
115°	RH	93.0	88.0	82.0	76.0	66.0	61.0	56.0	52.0	48.0	38.0	29.0	22.0	14.0	8.0	2.0	
	EMC	21.4	17.5	15.1	13.4	12.1	10.9	10.0	9.3	8.6	7.8	6.5	5.2	4.1	2.9	1.7	0.4
	DRI	0.2	0.4	0.5	0.7	0.9	1.0	1.2	1.3	1.4	1.6	1.9	2.1	2.4	2.6	2.8	2.9
120°	RH	94.0	88.0	82.0	77.0	72.0	67.0	62.0	58.0	53.0	49.0	40.0	31.0	24.0	17.0	10.0	15.0
	EMC	21.3	17.4	15.1	13.4	12.1	11.0	10.0	9.4	8.7	7.9	6.6	5.4	4.4	3.3	2.3	1.1
	DRI	0.2	0.4	0.6	0.8	1.0	1.1	1.3	1.4	1.6	1.8	2.1	2.4	2.6	2.9	3.1	3.3
125°	RH	94.0	88.0	83.0	77.0	73.0	68.0	63.0	59.0	55.0	51.0	41.0	33.0	26.0	19.0	13.0	8.0
	EMC	21.2	17.3	15.0	13.4	12.1	11.0	10.0	9.4	8.7	8.0	6.7	5.5	4.6	3.6	2.7	1.6
	DRI	0.2	0.5	0.7	0.9	1.1	1.3	1.5	1.6	1.8	1.9	2.3	2.7	2.9	3.2	3.4	3.6
130°	RH	94.0	89.0	83.0	78.0	73.0	69.0	64.0	60.0	56.0	52.0	43.0	35.0	28.0	21.0	15.0	10.0
	EMC	21.0	18.2	14.9	13.4	12.1	11.0	10.0	9.4	8.7	8.0	6.8	5.6	4.8	3.8	3.0	2.0
	DRI	0.3	0.5	0.8	1.0	1.1	1.4	1.6	1.8	2.0	2.2	2.6	2.9	3.3	3.6	3.9	4.1
140°	RH	95.0	89.0	84.0	79.0	75.0	70.0	66.0	62.0	58.0	54.0	46.0	38.0	31.0	25.0	19.0	14.0
	EMC	1.0	16.9	14.8	13.2	11.9	10.6	10.0	9.4	8.7	8.0	6.9	5.8	5.0	4.1	3.4	2.6
	DRI	0.3	0.6	0.9	1.2	1.5	1.8	2.0	2.2	2.5	2.7	3.2	3.7	4.1	4.4	4.8	5.1
150°	RH	95.0	90.0	85.0	80.0	76.0	72.0	68.0	64.0	60.0	57.0	48.0	41.0	35.0	28.0	23.0	18.0
	EMC	20.2	16.9	14.5	13.0	11.8	10.8	9.9	9.2	8.6	8.0	6.9	5.8	5.1	4.2	3.6	2.9
	DRI	0.4	0.8	1.1	1.5	1.8	2.1	2.4	2.7	3.0	3.3	3.9	4.5	5.0	5.5	5.8	6.2
160°	RH	95.0	90.0	86.0	81.0	77.0	73.0	69.0	65.0	62.0	58.0	50.0	43.0	37.0	31.0	25.0	21.0
	EMC	19.8	16.2	14.2	12.7	11.5	10.6	9.7	9.1	8.5	7.9	6.8	5.8	5.1	4.3	3.7	3.2
	DRI	0.5	1.0	1.4	1.8	2.2	2.6	3.0	3.4	3.7	4.1	4.8	5.5	6.1	6.7	7.2	7.6
170°	RH	95.0	91.0	86.0	82.0	78.0	74.0	70.0	67.0	63.0	60.0	52.0	45.0	39.0	33.0	28.0	24.0
	EMC	19.4	15.8	13.9	12.4	11.3	10.4	9.6	9.0	8.4	7.8	6.7	5.7	5.1	4.4	3.7	3.2
	DRI	0.6	1.1	1.7	2.2	2.7	3.2	3.7	4.0	4.5	4.9	5.9	6.7	7.5	8.2	8.8	9.3
180°	RH	96.0	91.0	87.0	83.0	79.0	75.0	72.0	68.0	65.0	62.0	54.0	47.0	41.0	35.0	30.0	26.0
	EMC	18.9	15.5	13.7	12.2	11.1	10.1	9.4	8.8	8.1	7.6	6.5	5.7	5.1	4.4	3.8	3.3
	DRI	0.6	1.4	2.0	2.6	3.2	3.8	4.3	4.9	5.4	5.8	7.0	8.1	9.0	10.0	10.7	11.3
190°	RH	96.0	92.0	88.0	84.0	80.0	76.0	73.0	69.0	66.0	63.0	56.0	49.0	43.0	37.0	32.0	28.0
	EMC	18.5	15.2	13.4	12.0	10.9	10.0	9.2	8.6	7.9	7.4	6.4	5.5	4.9	4.4	3.8	3.3
	DRI	0.8	1.5	2.3	3.0	3.8	4.6	5.1	5.9	6.5	7.0	8.4	9.7	10.9	12.0	12.9	13.7
200°	RH	96.0	92.0	88.0	84.0	80.0	77.0	84.0	80.0	77.0	72.0	64.0	51.0	45.0	39.0	34.0	30.0
	EMC	18.1	14.9	13.2	11.8	10.8	9.8	9.1	8.4	7.7	7.2	6.2	5.4	4.8	4.3	3.8	3.3
	DRI	0.9	1.9	2.8	3.8	4.7	5.4	6.1	7.0	7.8	8.5	10.1	11.5	13.0	14.3	15.5	16.4
210°	RH	96.0	92.0	88.0	85.0	81.0	78.0	75.0	71.0	68.0	65.0	59.0	52.0	46.0	41.0	36.0	32.0
	EMC	17.7	14.6	13.0	11.7	10.6	9.7	9.0	8.3	7.6	7.1	6.1	5.3	4.7	4.2	3.7	3.2
	DRI	1.2	2.3	3.5	4.3	5.5	6.3	7.2	8.3	9.2	10.1	11.8	16.8	15.5	17.0	18.4	19.6
DryBulb °F	Measurement	2°	4°	6°	8°	10°	12°	14°	16°	18°	20°	25°	30°	35°	40°	45°	50°

# Kiln Cart

Part # 30074061

VIEW ON KILNSTORE



## Cart Assembly

1. Install V Groove Wheels in the mounts using the wheel axle and flat washer; ensuring the wheels are oriented so the the grease fittings face outward. (See Fig A)

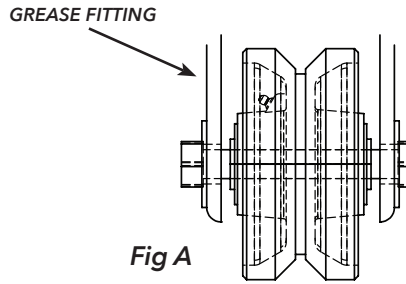

2. After installation layout the new installed cart frame out and place the rails on top aligning the holes. (see Fig B)

*Note: when placing the rails on the frame be sure to have the smaller holes facing the frame and larger holes facing up.*

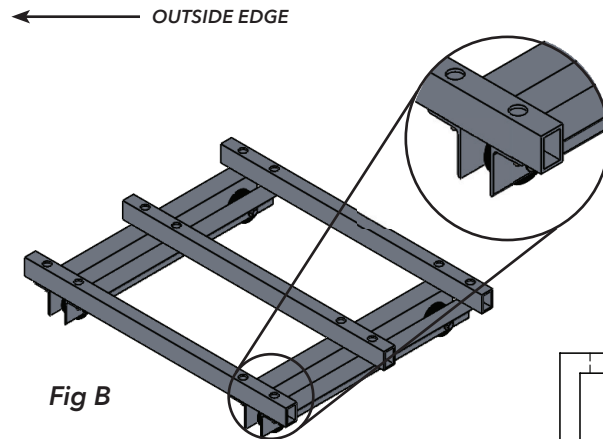

3. Install rails onto the base frame using the supplied bolts and locknuts. (See Fig C)

*Note: To tighten the bolts, go through the top holes in the rail with a ratchet, 3/4" socket and extender.*

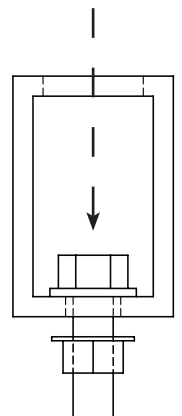

## Part List

Part No.	Description	Qty
10449657	3" x 2" x 48" Aluminum Kiln Cart Rails	3
10024662	1/2" x 4" Wheel Axle (with nuts attached)	4
31030000	38" Cart Base Frames	4
10527622	V Groove Wheels	4
10024658	1/2"-13 x 1 1/2" Stainless Steel Serrated Flange Bolt	12
10332242	1/2"-13 Stainless Steel Serrated Flange Locknut	12
10542460	5/8" Stainless Steel Flat Washer	8

# Wiring Diagrams

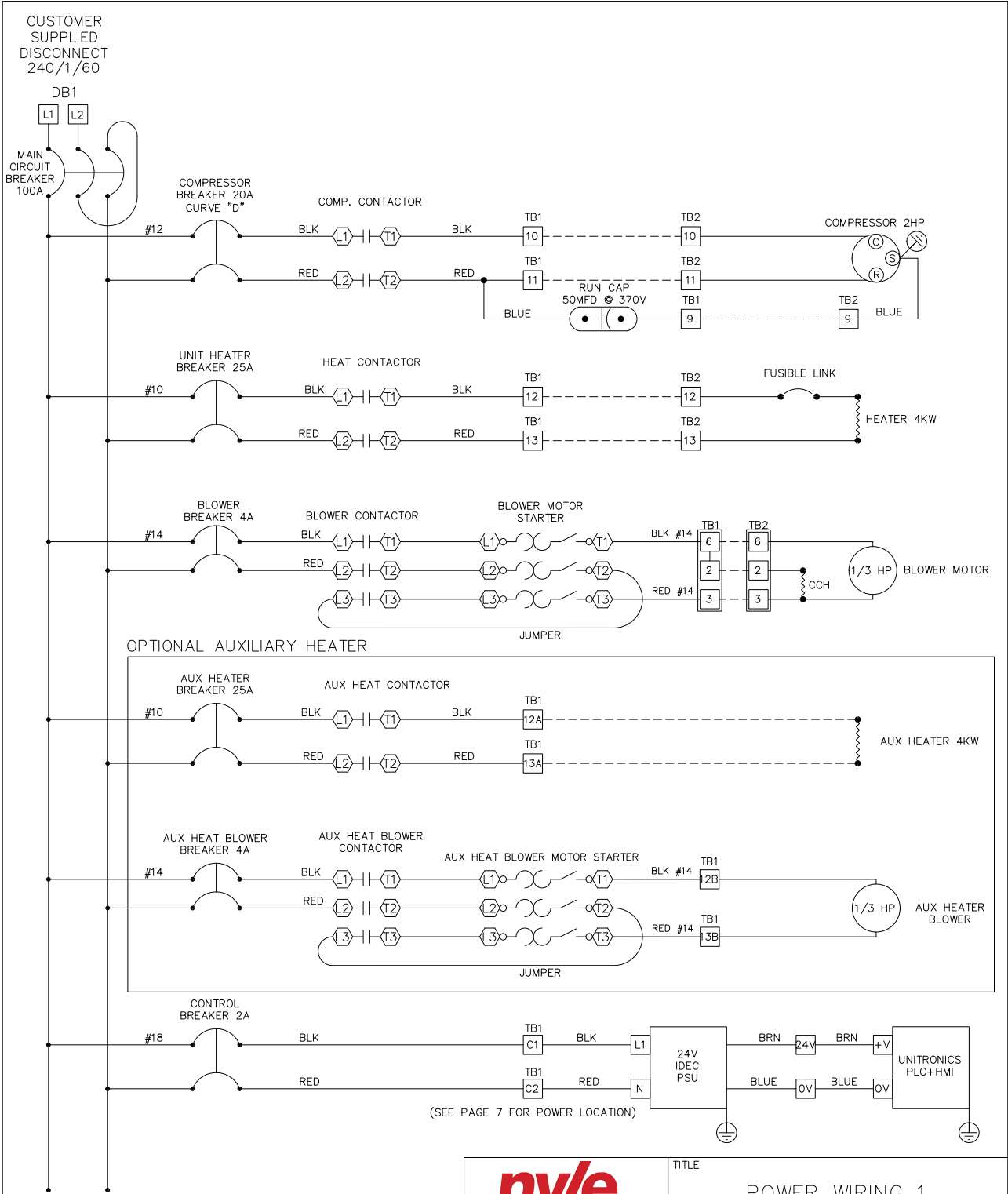

CONTINUED ON PG. 2

<p style="font-size: 8px; margin-top: 5px;">12 Stevens Road Brewer, Maine 04412 Tel: 1-207-989-4335 Int'l: 1-800-777-6953 Fax: 1-207-989-1101 Email: info@nyle.com</p>	TITLE POWER WIRING 1	
	UNIT L200PR08 CONTROL PANEL	
DRAWN BY KK	BOM PN 30074060	REV 2023.2.2
CHECKED DA	SCALE NTS	SHEET 1 OF 7

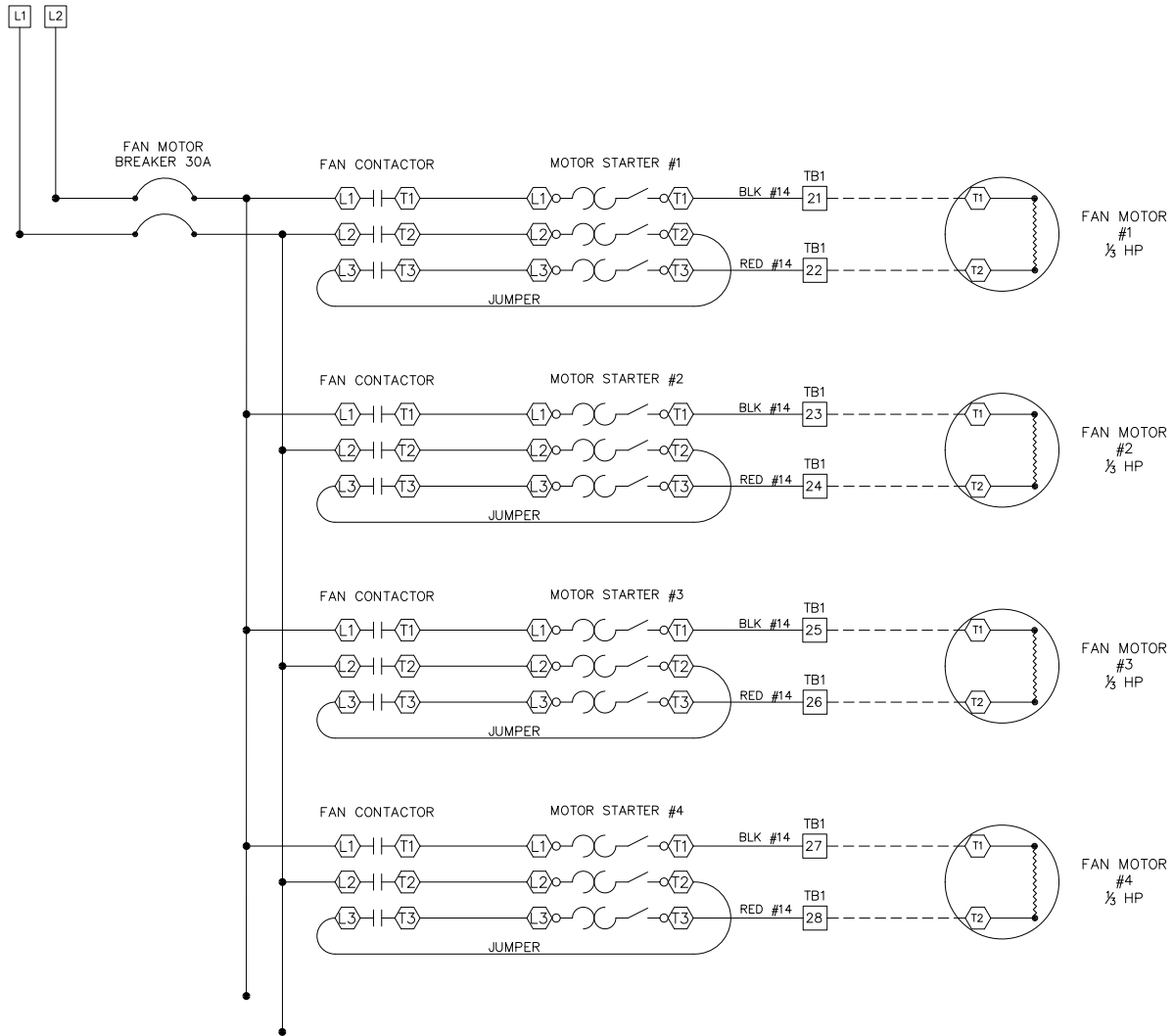

FANS 5-8  
CONT. ON  
NEXT SHEET

 <small>12 Stevens Road Brewer, Maine 04412 Tel: 1-207-989-4335 Int'l: 1-800-777-6953 Fax: 1-207-989-1101 Email: info@nyle.com</small>	TITLE	
	POWER WIRING 2	
DRAWN BY KK	UNIT	
	L200PR08 CONTROL PANEL	
CHECKED DA	BOM PN	REV
	30074060	2023.2.2
	SCALE	SHEET
	NTS	2 OF 7

CONT. FROM  
PREV. SHEET

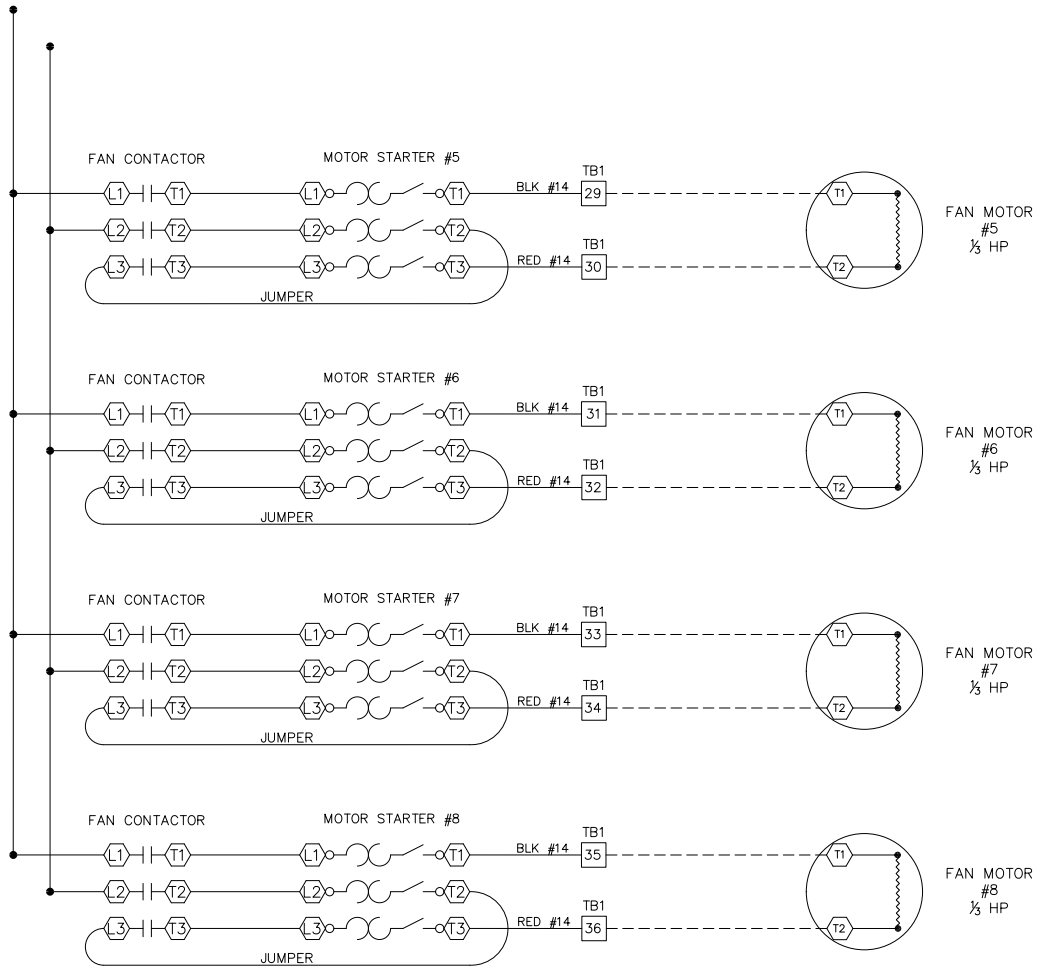

 <small>12 Stevens Road Brewer, Maine 04412 Tel: 1-207-989-4335 Int'l: 1-800-777-6953 Fax: 1-207-989-1101 Email: info@nyle.com</small>	TITLE	
	POWER WIRING 3	
DRAWN BY KK	UNIT	
	L200PR08 CONTROL PANEL	
CHECKED DA	BOM PN	REV
	30074060	2023.2.2
	SCALE	SHEET
	NTS	3 OF 7

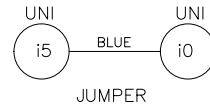
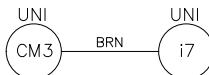
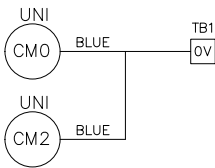
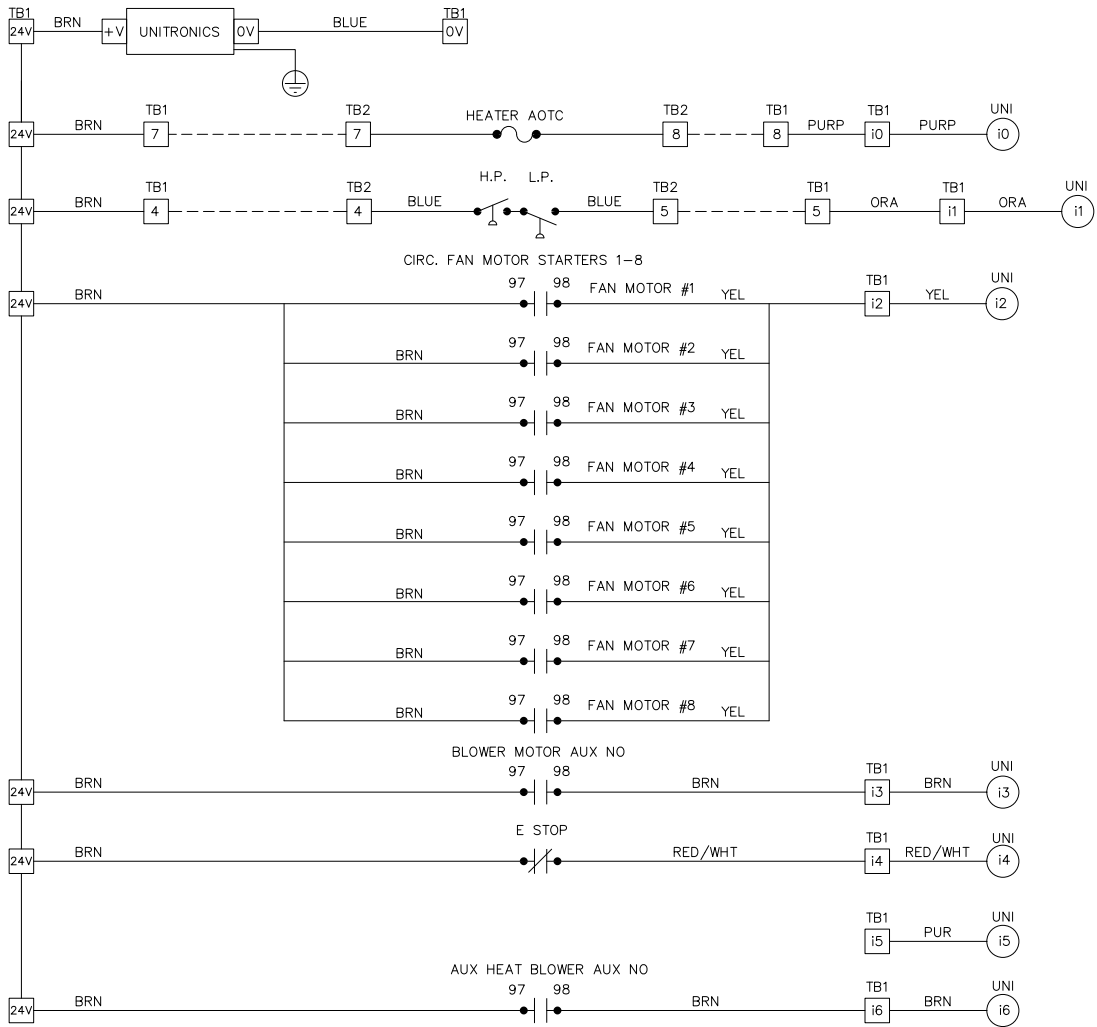

OPTIONAL JUMPER  
 OPEN = FAHRENHEIT (FACTORY DEFAULT)  
 CLOSED = CELSIUS

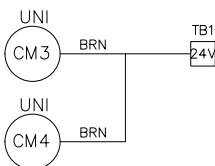

 <small>12 Stevens Road          Brewer, Maine 04412          Tel: 1-207-989-4335          Int'l: 1-800-777-6953          Fax: 1-207-989-1101          Email: info@nyle.com</small>	TITLE	
	INPUT WIRING 1	
DRAWN BY <b>KK</b>	UNIT	
	L200PRO8 CONTROL PANEL	
CHECKED	BOM PN	REV
	30074060	2023.2.2
DA	SCALE	SHEET
	NTS	1 OF 7

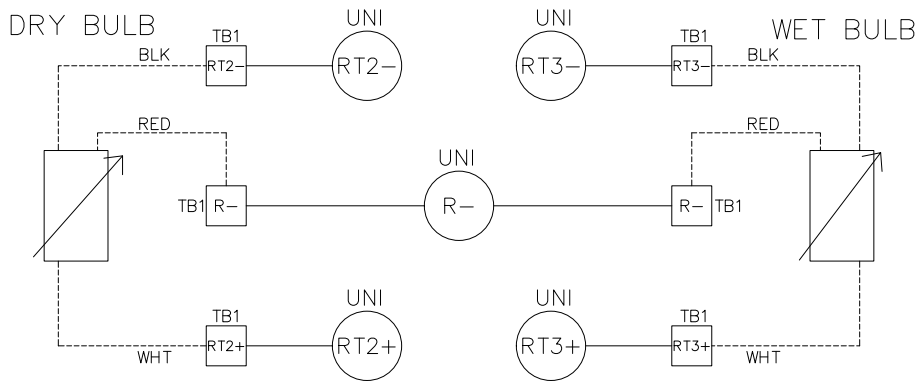
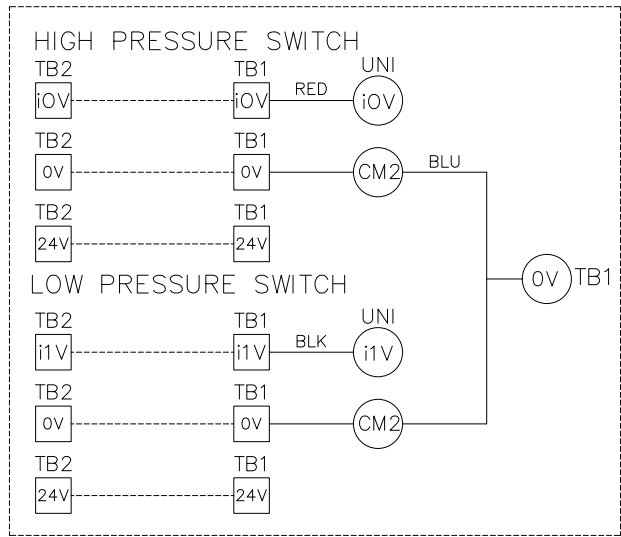

EE071/RS485

EE072

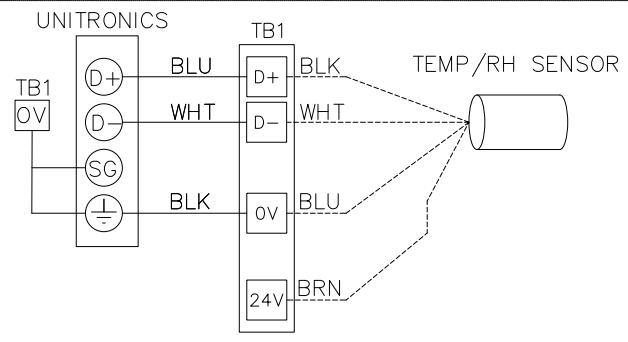
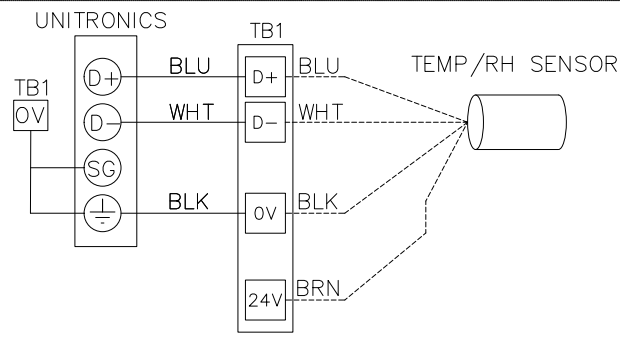



FIELD WIRING = -----  
 FACTORY WIRING = \_\_\_\_\_

 12 Stevens Road Brewer, Maine 04412 Tel: 1-207-989-4335 Int'l: 1-800-777-6953 Fax: 1-207-989-1101 Email: info@nyle.com	TITLE		INPUT WIRING 2
	UNIT		L200PRO8 CONTROL PANEL
DRAWN BY	BOM PN	REV	
KK	30074060	2023.2.2	
CHECKED	SCALE	SHEET	
DA	NTS	5 OF 7	

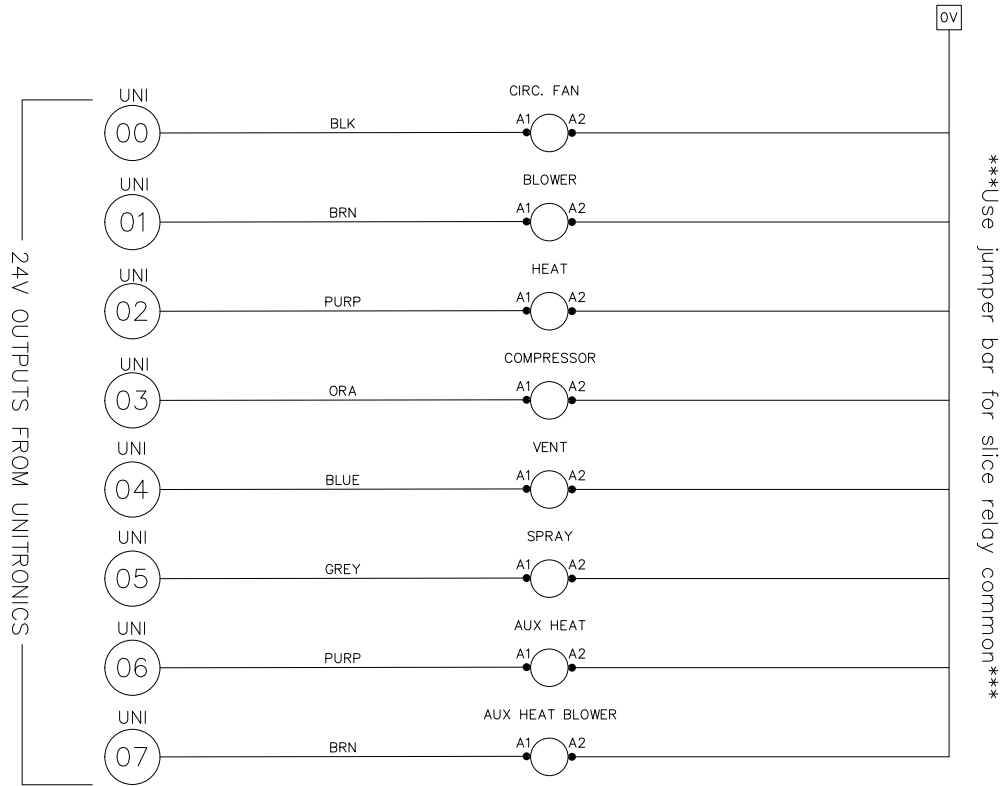

OUTPUTS TO SLICE RELAYS



 12 Stevens Road Brewer, Maine 04412 Tel: 1-207-989-4335 Int'l: 1-800-777-6953 Fax: 1-207-989-1101 Email: info@nyle.com	TITLE	
	OUTPUT WIRING 1	
	UNIT	
	L200PR08 CONTROL PANEL	
DRAWN BY	BOM PN	REV
KK	30074060	2023.2.2
CHECKED	SCALE	SHEET
DD	NTS	6 OF 7

OUTPUTS FROM SLICE RELAYS

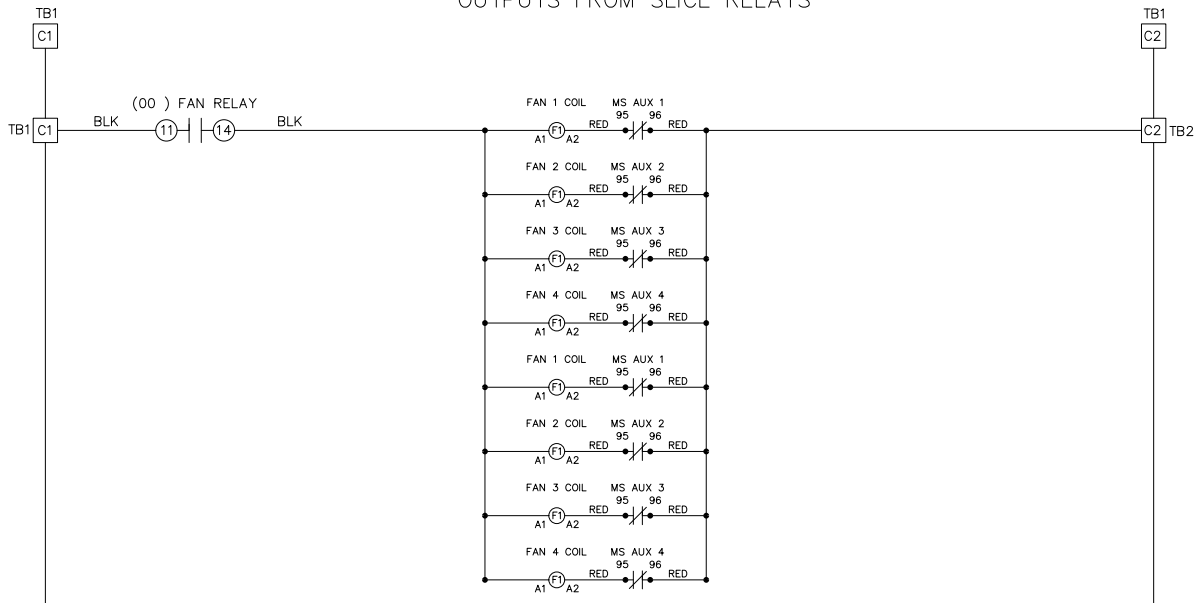

WIRE MOTOR STARTER IN AS SHOWN BELOW BASED ON WHICH TYPE OF MOTOR STARTER IS AVAILABLE

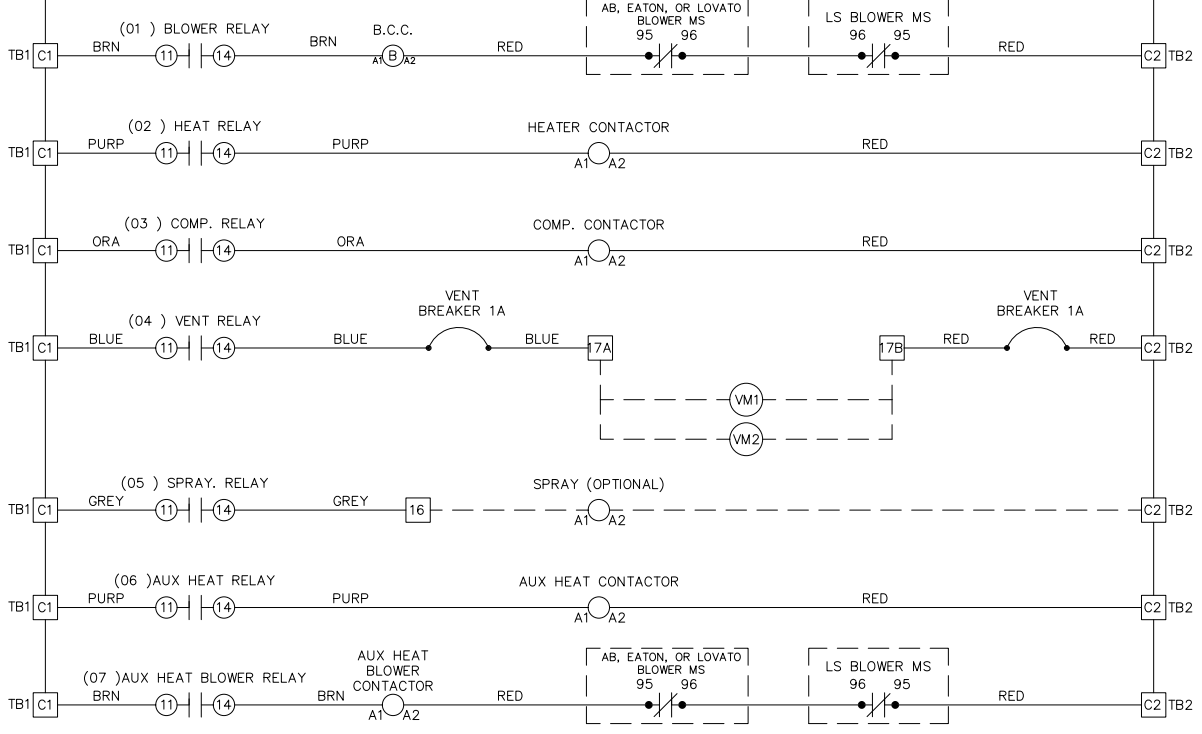

WIRE MOTOR STARTER IN AS SHOWN BELOW BASED ON WHICH TYPE OF MOTOR STARTER IS AVAILABLE

 <p>12 Stevens Road Brewer, Maine 04412 Tel: 1-207-989-4335 Int'l: 1-800-777-6953 Fax: 1-207-989-1101 Email: info@nyle.com</p>	TITLE OUTPUT WIRING 2	
	UNIT L200PRO8 CONTROL PANEL	
DRAWN BY KK	BOM PN 30074060	REV 2023.2.2
CHECKED DA	SCALE NTS	SHEET 7 OF 7

# L200 Maintenance

---

## General Maintenance

The L200 is designed for continuous duty, with little maintenance. However, when a problem does arise prompt repair will ensure long life for the machine.

The blower system is direct drive and the motor has sealed high temperature ball bearings. This unit does not need regular maintenance.

The circulating fan system is also direct drive with a ball bearing motor. The motor does not require lubrication.

## Air Inlet Filters

The air filters are provided to keep the air inside the unit as clean as possible. Dirt build-up on the coils will lead to poor heat transfer with loss of capacity.

In extreme cases, the coil will completely clog. The air filter should be washed when dirty and replaced when necessary. If the filter becomes clogged, the air supply will be drastically reduced, causing the heater to overheat and the refrigeration system to overload. Evap coil should be kept clean. Clean with dish soap and water.

## Refrigerant Charging Procedure

The refrigeration system is a closed loop system with its own lubrication oil supply. Nyle uses only the best trade practices when assembling these systems. The system should give years of trouble free service. However, if the system is not removing the right amount of water, or if a problem should arise from rough shipping or a refrigeration leak, the system should only be looked at and worked on by a qualified refrigeration mechanic.

When the system experiences reduced water output, this is generally associated with a leak in the refrigeration system. If the leak is found and repaired before the system is empty, there is little chance that the system will be contaminated with moisture. If the system is ignored for a long period of time, moisture can enter the system and combine with the refrigerant to form acid. The system will then corrode from the inside-out if not corrected properly.

*Warning: Refrigeration professionals should use caution, these refrigeration conditions are uncommon.*

These systems operate over a very wide temperature and humidity range. The pressures will be relatively high when compared to air conditioners and heat pumps. For these reasons, you cannot charge by the sight glass, the sight glass will eventually clear at certain conditions but it is unlikely that those conditions will exist when servicing.

If the kiln is loaded with lumber, it will be very dangerous to run the kiln at extreme limits, as the lumber will degrade severely. With this danger factor and the factor of time involved of heating the kiln, Nyle insists that these machines have weighed in charge. The amount is as follows:

L200 60 oz. R134a

**CALL NYLE IF YOUR TECHNICIAN LACKS THE RECOMMENDED REFRIGERANT. WE CAN RECOMMEND ALTERNATIVES.**

## Appendix

---

### Terminology

**DRY BULB:** The temperature as measured by a thermometer.

**WET BULB:** The temperature of a thermometer with a wet wick over the sensor.

**WET BULB DEPRESSION:** The difference between the dry bulb temperature and the wet bulb temperature.

Example: if the dry bulb is 105° F. and the wet bulb is 98° F., the depression is 105° F. - 98° F., or 7° F.

**RH-RELATIVE HUMIDITY:** The ratio of the amount of water in the air to what the air could hold. At 50% RH, the air has 50% as much water in it as it would hold at 100% RH. 100% is a 0° F. depression.

**EMC-EQUILIBRIUM MOISTURE CONTENT:** This is the average moisture content all wood will reach eventually when exposed to these conditions.

**DRI-DRYING RATE INDEX:** This is an index of relative drying rate.

<b>Problem</b>	<b>Possible Causes / Actions</b>	<b>Corrections</b>
<b>Circulating Fan(s) won't Start</b>	<ul style="list-style-type: none"> <li>• New Install: Check your wiring</li> <li>• Existing System: Check your amp draw</li> <li>• Check motor rotation for signs of sticking or grinding.</li> </ul>	<ul style="list-style-type: none"> <li>• Rewire or tighten connections.</li> <li>• If amps are high: check capacitors, replace if needed.</li> <li>• If rotation is sticking or grinding, bearings or bushing are bad, replace motor.</li> </ul>
<b>Unit won't Start</b>	<ul style="list-style-type: none"> <li>• Control Switch Tripping</li> <li>• Check Power</li> </ul>	<ul style="list-style-type: none"> <li>• Rewire or tighten connections.</li> <li>• Check capacitors, replace if needed.</li> <li>• If Switch keeps tripping, replace switch.</li> </ul>
<b>No Heat</b>	<ul style="list-style-type: none"> <li>• Check that the automatic over temperature control switch (AOTC) is in auto position &amp; the control is calling for heat, use wiring diagram to check heat circuit.</li> <li>• Check fusible link</li> <li>• Check heater coil</li> </ul>	<ul style="list-style-type: none"> <li>• Replace the AOTC or fusible link if bad.</li> <li>• Replace whole heater if coil is bad.</li> </ul>
<b>Compressor doesn't run</b>	<ul style="list-style-type: none"> <li>• High Pressure Switch has tripped</li> <li>• Fault in circuit</li> </ul>	<ul style="list-style-type: none"> <li>• Reset High Pressure Switch.</li> <li>• With a multimeter and wiring diagram check if: <ul style="list-style-type: none"> <li>• Low Pressure switch tripped ; call nyle.</li> <li>• Time delay relay is bad; Replace if it is.</li> <li>• Compressor has power ; call nyle if it does.</li> </ul> </li> </ul>
<b>Unit Starts and Runs but Screen is Dead</b>	<ul style="list-style-type: none"> <li>• Bad fuse in controller</li> </ul>	<ul style="list-style-type: none"> <li>• Check fuse if fuse is bad, call nyle.</li> </ul>
<b>Water isn't Draining</b>	<ul style="list-style-type: none"> <li>• Issue with drain line/ trap</li> </ul>	<ul style="list-style-type: none"> <li>• Clear any blockages in drain line / trap.</li> <li>• Add trap to drain line if no trap installed.</li> </ul>
<b>Temperature is flashing ERR or both Wet &amp; Dry Bulb</b>	<ul style="list-style-type: none"> <li>• Wet bulb too high</li> <li>• Wet bulb equals Dry bulb</li> </ul>	<ul style="list-style-type: none"> <li>• Check Wet bulb bottle for water.</li> <li>• Check Wet bulb wick.</li> <li>• Make sure Wet bulb temperature doesn't equal Dry Bulb Temp.</li> </ul>



Still need help? Check out our video series KilnTECH on YouTube for more support



**Fusible Link**  
**Automatic Over Temperature Control Switch (AOTC)**

# Upgrades & Accessories

## Spray Systems Kit

Although not standard on Nyle DH Kilns you may choose to add on this optional Spray System Kit which will provide extra control when drying. The Sprayers are designed to be automatically activated by the system when needed and help with regulating the relative humidity within the kiln chamber.

Nyle spray systems are designed to inject into kiln air one gallon of water per hour for every 1000 BF. Because air temperature affects the quantity of water evaporated (warmer air holds more water vapor), we need to balance the quantity of water vapor to the kiln capacity. DH units with small heaters will require proportionately less water than larger units with bigger heating capacity. There are options available for every unit so be sure that the kit you are purchasing matches the specifications for the unit that it will be installed in.

Nyle encourages boosting water pressure to 100 psi for the spray system to have the best results. Commonly this is done with the use of a jet pump, which can be purchased through Nyle if requested. Contact your Nyle Sales or Service Representative for more information. You can reach a Nyle Service Professional by:

Calling us directly at (800)777-6953 X 212 or by sending us an email at [service@nyle.com](mailto:service@nyle.com)

## Heat Booster Packages



The Heat Booster is an auxiliary heater that can be connected to the control and provide additional heat and airflow within the kiln. This upgrade is used to;

**Set Pitch:** The heat booster allows the kiln temperature to reach 160° F to set the pitch and prevent any future running.

*Note: Pitch setting is only required when drying Pine.*

**Sterilize the Load:** By the kiln reaching 160° F it also sterilizes the load. During this sterilization process any bugs or mold in the wood is killed off.

The heat booster is also used to increase the speed at which the kiln chamber heats to the desired temperature. This becomes useful for when you have a larger chambers.

CONTROL ROOM ASSEMBLY OF SOLENOID VALVE, STRAINER, AND REGULATOR

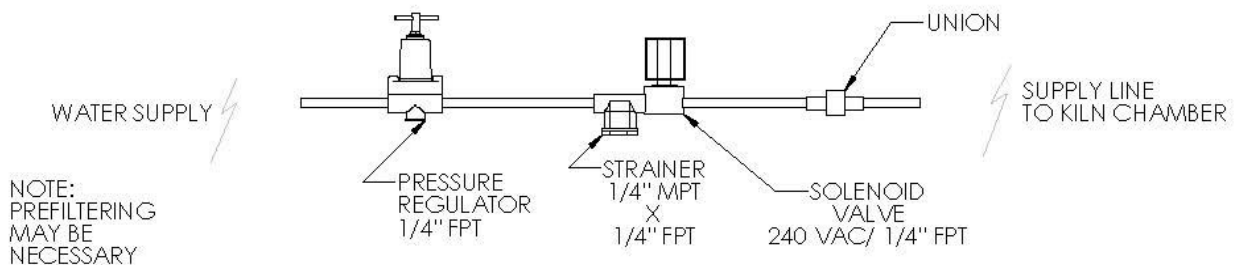

LOCATE SUPPLY LINE IN A CONVENIENT LOCATION

ELECTICAL CONNECTIONS:  
WIRE THE SOLENOID VALVE BACK TO NYLE ELECTRICAL PANEL AND CONNECT TO TB1 [16] AND [N]

## Kiln Store

---

Nyle Systems likes to be there for our clients whether they have just bought a new kiln or if they have owned a Nyle kiln for years. It is because of this that we try to make replacement parts easily accessible right Online in our Kiln Store.

From The Kiln Store you can find many parts, equipment and accessories for both conventional kilns and DH kilns. Anything and everything you need to keep your Nyle Kiln running for years to come. We even sell parts supplies that will fit Non-Nyle kilns if you need them.

At The Kiln Store you can expect to find everything you need including:

- Accessory Kits
- Controls and Control Accessories
- Additional Heaters and Fans
- Sample Testing Supplies and Charts
- Replacement Meters, Probes and Sensors
- Replacement Belts, Filters and Parts

So when you need a part for your kiln you don't have to look any further than [www.nyle.com](http://www.nyle.com) to find exactly what you need.

If you ever need assistance don't forget Nyle's star service team is always available to help you whether its finding the right replacement part or purchasing additional accessories for upgrades.

Contact your Nyle Sales or Service Representative for more information. You can reach a Nyle Service Professional by:

Calling us directly at (800)777-6953 X 212 or by sending us an email at [service@nyle.com](mailto:service@nyle.com)

## Warranty

---

LIMITED WARRANTY: The equipment supplied by Nyle Dry Kilns is warranted to be free from defects in workmanship and materials for a period of one year from the date of the original installation under normal use and maintenance, or 15 months from the date of delivery, whichever comes first. A new or re-manufactured part will be supplied by Nyle Dry Kilns if the defective part is first returned to Nyle Dry Kilns for inspection. The replacement part assumes the unused portion of the warranty. The warranty does not include labor or other costs incurred for diagnosis, repairing or removing, installing or shipping the defective or replacement part(s). Nyle Dry Kilns makes no warranty as to the fitness of the equipment for a particular use and shall not be liable for any direct, indirect or consequential damages in conjunction with this contract and/or the use of its equipment. Buyer agrees to indemnify and save harmless Nyle Dry Kilns from any claims or demands against Nyle Dry Kilns for injuries or damages to the third parties resulting from buyer's use or ownership of the equipment. No other warranties, expressed or implied, will be honored unless in writing by an authorized officer of Nyle Dry Kilns.

Model \_\_\_\_\_

Serial Number \_\_\_\_\_

Date Purchased \_\_\_\_\_













**nyle**  
Dry Kilns



*Check out our complete line of videos providing tips on kiln drying and preventative maintenance*

**nyle**  
**KILN IQ**



**nyle**  
**KILN TECH**